

# CHAPTER 7

## WALL COVERING

### SECTION R701 GENERAL

**R701.1 Application.** The provisions of this chapter shall control the design and construction of the interior and exterior wall covering for all buildings.

**Exception:** Buildings and structures located within the High-Velocity Hurricane Zone shall comply with the provisions of Chapter 44.

**R701.2 Installation.** Products sensitive to adverse weather shall not be installed until adequate weather protection for the installation is provided. Exterior sheathing shall be dry before applying exterior cover.

**TABLE R702.1(1)  
THICKNESS OF PLASTER**

PLASTER BASE	FINISHED THICKNESS OF PLASTER FROM FACE OF LATH, MASONRY, CONCRETE (inches)	
	Gypsum Plaster	Cement Plaster
Expanded metal lath	$\frac{5}{8}$ , minimum <sup>a</sup>	$\frac{5}{8}$ , minimum <sup>a</sup>
Wire lath	$\frac{5}{8}$ , minimum <sup>a</sup>	$\frac{3}{4}$ , minimum (interior) <sup>b</sup> $\frac{7}{8}$ , minimum (exterior) <sup>b</sup>
Gypsum lath <sup>g</sup>	$\frac{1}{2}$ , minimum	$\frac{3}{4}$ , minimum (interior) <sup>b</sup>
Masonry walls <sup>c</sup>	$\frac{1}{2}$ , minimum	$\frac{1}{2}$ , minimum
Monolithic concrete walls <sup>c, d</sup>	$\frac{5}{8}$ , maximum	$\frac{7}{8}$ , maximum
Monolithic concrete ceilings <sup>c, d</sup>	$\frac{3}{8}$ , maximum <sup>e</sup>	$\frac{1}{2}$ , maximum
Gypsum veneer base <sup>f, g</sup>	$\frac{1}{16}$ , minimum	$\frac{3}{4}$ , minimum (interior) <sup>b</sup>
Gypsum sheathing <sup>g</sup>	—	$\frac{3}{4}$ , minimum (interior) <sup>b</sup> $\frac{7}{8}$ , minimum (exterior) <sup>b</sup>

For SI: 1 inch = 25.4 mm.

- When measured from back plane of expanded metal lath, exclusive of ribs, or self-furring lath, plaster thickness shall be  $\frac{3}{4}$  inch minimum.
- When measured from face of support or backing.
- Because masonry and concrete surfaces may vary in plane, thickness of plaster need not be uniform.
- When applied over a liquid bonding agent, finish coat may be applied directly to concrete surface.
- Approved acoustical plaster may be applied directly to concrete or over base coat plaster, beyond the maximum plaster thickness shown.
- Attachment shall be in accordance with Table R702.3.5.
- Where gypsum board is used as a base for cement plaster, a water-resistive barrier complying with Section R703.2 shall be provided.

**TABLE R702.1(2)  
GYPSUM PLASTER PROPORTIONS<sup>a</sup>**

NUMBER	COAT	PLASTER BASE OR LATH	MAXIMUM VOLUME AGGREGATE PER 100 POUNDS NEAT PLASTER <sup>b</sup> (cubic feet)	
			Damp Loose Sand <sup>a</sup>	Perlite or Vermiculite <sup>c</sup>
Two-coat work	Base coat	Gypsum lath	2.5	2
	Base coat	Masonry	3	3
Three-coat work	First coat	Lath	2 <sup>d</sup>	2
	Second coat	Lath	3 <sup>d</sup>	2 <sup>e</sup>
	First and second coats	Masonry	3	3

For SI: 1 inch = 25.4 mm, 1 cubic foot = 0.0283 m<sup>3</sup>, 1 pound = 0.454 kg.

- Wood-fibered gypsum plaster may be mixed in the proportions of 100 pounds of gypsum to not more than 1 cubic foot of sand where applied on masonry or concrete.
- When determining the amount of aggregate in set plaster, a tolerance of 10 percent shall be allowed.
- Combinations of sand and lightweight aggregate may be used, provided the volume and weight relationship of the combined aggregate to gypsum plaster is maintained.
- If used for both first and second coats, the volume of aggregate may be 2.5 cubic feet.
- Where plaster is 1 inch or more in total thickness, the proportions for the second coat may be increased to 3 cubic feet.

**TABLE R702.1(3)  
CEMENT PLASTER PROPORTIONS, PARTS BY VOLUME**

COAT	CEMENT PLASTER TYPE	CEMENTITIOUS MATERIALS				VOLUME OF AGGREGATE PER SUM OF SEPARATE VOLUMES OF CEMENTITIOUS MATERIALS <sup>b</sup>
		Portland Cement Type I, II or III or Blended Cement Type IP, I (PM), IS or I (SM)	Plastic Cement	Masonry Cement Type M, S or N	Lime	
First	Portland or blended	1			<sup>3</sup> / <sub>4</sub> - 1 <sup>1</sup> / <sub>2</sub> <sup>a</sup>	2 <sup>1</sup> / <sub>2</sub> - 4
	Masonry				1	2 <sup>1</sup> / <sub>2</sub> - 4
	Plastic		1			2 <sup>1</sup> / <sub>2</sub> - 4
Second	Portland or blended	1			<sup>3</sup> / <sub>4</sub> - 1 <sup>1</sup> / <sub>2</sub>	3 - 5
	Masonry			1		3 - 5
	Plastic		1			3 - 5
Finish	Portland or blended	1			<sup>3</sup> / <sub>4</sub> - 2	1 <sup>1</sup> / <sub>2</sub> - 3
	Masonry			1		1 <sup>1</sup> / <sub>2</sub> - 3
	Plastic		1			1 <sup>1</sup> / <sub>2</sub> - 3

For SI: 1 inch = 25.4 mm, 1 pound = 0.545 kg.

- a. Lime by volume of 0 to <sup>3</sup>/<sub>4</sub> shall be used when the plaster will be placed over low-absorption surfaces such as dense clay tile or brick.
- b. The same or greater sand proportion shall be used in the second coat than used in the first coat.

**TABLE R702.3.5  
MINIMUM THICKNESS AND APPLICATION OF GYPSUM BOARD**

THICKNESS OF GYPSUM BOARD (inches)	APPLICATION	ORIENTATION OF GYPSUM BOARD TO FRAMING	MAXIMUM SPACING OF FRAMING MEMBERS (inches o.c.)	MAXIMUM SPACING OF FASTENERS (inches)		SIZE OF NAILS FOR APPLICATION TO WOOD FRAMING <sup>c</sup>
				Nails <sup>a</sup>	Screws <sup>b</sup>	
<b>Application without adhesive</b>						
<sup>3</sup> / <sub>8</sub>	Ceiling <sup>d</sup>	Perpendicular	16	7	12	13 gage, 1 <sup>1</sup> / <sub>4</sub> " long, <sup>19</sup> / <sub>64</sub> " head; 0.098" diameter, 1 <sup>1</sup> / <sub>4</sub> " long, annular-ringed; or 4d cooler nail, 0.080" diameter, 1 <sup>3</sup> / <sub>8</sub> " long, <sup>7</sup> / <sub>32</sub> " head.
	Wall	Either direction	16	8	16	
<sup>1</sup> / <sub>2</sub>	Ceiling	Either direction	16	7	12	13 gage, 1 <sup>3</sup> / <sub>8</sub> " long, <sup>19</sup> / <sub>64</sub> " head; 0.098" diameter, 1 <sup>1</sup> / <sub>4</sub> " long, annular-ringed; 5d cooler nail, 0.086" diameter, 1 <sup>5</sup> / <sub>8</sub> " long, <sup>15</sup> / <sub>64</sub> " head; or gypsum board nail, 0.086" diameter, 1 <sup>5</sup> / <sub>8</sub> " long, <sup>9</sup> / <sub>32</sub> " head.
	Ceiling <sup>d</sup>	Perpendicular	24	7	12	
	Wall	Either direction	24	8	12	
<sup>5</sup> / <sub>8</sub>	Wall	Either direction	16	8	16	13 gage, 1 <sup>5</sup> / <sub>8</sub> " long, <sup>19</sup> / <sub>64</sub> " head; 0.098" diameter, 1 <sup>3</sup> / <sub>8</sub> " long, annular-ringed; 6d cooler nail, 0.092" diameter, 1 <sup>7</sup> / <sub>8</sub> " long, <sup>1</sup> / <sub>4</sub> " head; or gypsum board nail, 0.0915" diameter, 1 <sup>7</sup> / <sub>8</sub> " long, <sup>19</sup> / <sub>64</sub> " head.
	Ceiling	Either direction	16	7	12	
	Ceiling <sup>e</sup>	Perpendicular	24	7	12	
	Wall	Either direction	24	8	12	
<sup>3</sup> / <sub>8</sub>	<b>Application with adhesive</b>					
	Wall	Either direction	16	16	16	Same as above for <sup>3</sup> / <sub>8</sub> " gypsum board
<sup>1</sup> / <sub>2</sub> or <sup>5</sup> / <sub>8</sub>	Ceiling <sup>d</sup>	Perpendicular	16	16	16	
	Ceiling	Either direction	16	16	16	
	Wall	Either direction	24	16	24	
Two <sup>3</sup> / <sub>8</sub> layers	Ceiling	Perpendicular	16	16	16	Base ply nailed as above for <sup>1</sup> / <sub>2</sub> " gypsum board; face ply installed with adhesive
	Wall	Either direction	24	24	24	

For SI: 1 inch = 25.4 mm.

- a. For application without adhesive, a pair of nails spaced not less than 2 inches apart or more than 2<sup>1</sup>/<sub>2</sub> inches apart may be used with the pair of nails spaced 12 inches on center.
- b. Screws shall be in accordance with Section R702.3.6. Screws for attaching gypsum board to structural insulated panels shall penetrate the wood structural panel facing not less than <sup>7</sup>/<sub>16</sub> inch.
- c. Where cold-formed steel framing is used with a clinching design to receive nails by two edges of metal, the nails shall be not less than <sup>5</sup>/<sub>8</sub> inch longer than the gypsum board thickness and shall have ringed shanks. Where the cold-formed steel framing has a nailing groove formed to receive the nails, the nails shall have barbed shanks or be 5d, 13<sup>1</sup>/<sub>2</sub> gage, <sup>15</sup>/<sub>8</sub> inches long, <sup>15</sup>/<sub>64</sub>-inch head for <sup>1</sup>/<sub>2</sub>-inch gypsum board; and 6d, 13 gage, 1<sup>1</sup>/<sub>8</sub> inches long, <sup>15</sup>/<sub>64</sub>-inch head for <sup>5</sup>/<sub>8</sub>-inch gypsum board.
- d. Three-eighths-inch-thick single-ply gypsum board shall not be used on a ceiling where a water-based textured finish is to be applied, or where it will be required to support insulation above a ceiling. On ceiling applications to receive a water-based texture material, either hand or spray applied, the gypsum board shall be applied perpendicular to framing. When applying a water-based texture material, the minimum gypsum board thickness shall be increased from <sup>3</sup>/<sub>8</sub> inch to <sup>1</sup>/<sub>2</sub> inch for 16-inch on center framing, and from <sup>1</sup>/<sub>2</sub> inch to <sup>5</sup>/<sub>8</sub> inch for 24-inch on center framing or <sup>1</sup>/<sub>2</sub>-inch sag-resistant gypsum ceiling board shall be used.
- e. Type X gypsum board for garage ceilings beneath habitable rooms shall be installed perpendicular to the ceiling framing and shall be fastened at maximum 6 inches o.c. by minimum 1<sup>7</sup>/<sub>8</sub> inches 6d coated nails or equivalent drywall screws.

## SECTION R702 INTERIOR COVERING

**R702.1 General.** Interior coverings or wall finishes shall be installed in accordance with this chapter and Table R702.1(1), Table R702.1(2), Table R702.1(3) and Table R702.3.5. Interior masonry veneer shall comply with the requirements of Section R703.7.1 for support and Section R703.7.4 for anchorage, except an air space is not required. Interior finishes and materials shall conform to the flame spread and smoke-development requirements of Section R302.9.

### R702.2 Interior plaster.

**R702.2.1 Gypsum plaster.** Gypsum plaster materials shall conform to ASTM C 5, C 28, C 35, C 37, C 59, C 61, C 587, C 588, C 631, C 847, C 933, C 1032 and C 1047, and shall be installed or applied in conformance with ASTM C 843 and C 844. Plaster shall not be less than three coats when applied over metal lath and not less than two coats when applied over other bases permitted by this section, except that veneer plaster may be applied in one coat not to exceed  $\frac{3}{16}$  inch (4.76 mm) thickness, provided the total thickness is in accordance with Table R702.1(1).

**R702.2.2 Cement plaster.** Cement plaster materials shall conform to ASTM C 37, C 91 (Type M, S or N), C 150 (Type I, II and III), C 588, C 595 [Type IP, I (PM), IS and I (SM)], C 847, C 897, C 926, C 933, C 1032, C 1047 and C 1328, and shall be installed or applied in conformance with ASTM C 1063. Plaster shall not be less than three coats when applied over metal lath and not less than two coats when applied over other bases permitted by this section, except that veneer plaster may be applied in one coat not to exceed  $\frac{3}{16}$  inch (4.76 mm) thickness, provided the total thickness is in accordance with Table R702.1(1).

**R702.2.2.1 Application.** Each coat shall be kept in a moist condition for at least 24 hours prior to application of the next coat.

**Exception:** Applications installed in accordance with ASTM C 926.

**R702.2.2.2 Curing.** The finish coat for two-coat cement plaster shall not be applied sooner than 48 hours after application of the first coat. For three coat cement plaster the second coat shall not be applied sooner than 24 hours after application of the first coat. The finish coat for three-coat cement plaster shall not be applied sooner than 48 hours after application of the second coat.

**R702.2.3 Support.** Support spacing for gypsum or metal lath on walls or ceilings shall not exceed 16 inches (406 mm) for  $\frac{3}{8}$  inch thick (9.5 mm) or 24 inches (610 mm) for  $\frac{1}{2}$ -inch-thick (12.7 mm) plain gypsum lath. Gypsum lath shall be installed at right angles to support framing with end joints in adjacent courses staggered by at least one framing space.

### R702.3 Gypsum board.

**R702.3.1 Materials.** All gypsum board materials and accessories shall conform to ASTM C 36, C 79, C 475, C 514, C 630, C 931, C 960, C 1002, C 1047, C 1177, C 1178, C 1278, C 1395, C 1396 or C 1658 and shall be installed in

accordance with the provisions of this section. Adhesives for the installation of gypsum board shall conform to ASTM C 557.

**R702.3.2 Wood framing.** Wood framing supporting gypsum board shall not be less than 2 inches (51 mm) nominal thickness in the least dimension except that wood furring strips not less than 1-inch-by-2 inch (25 mm by 51 mm) nominal dimension may be used over solid backing or framing spaced not more than 24 inches (610 mm) on center.

**R702.3.3 Cold-formed steel framing.** Cold-formed steel framing supporting gypsum board shall not be less than  $1\frac{1}{4}$  inches (32 mm) wide in the least dimension. Nonload-bearing cold-formed steel framing shall comply with ASTM C 645. Load-bearing cold-formed steel framing and all cold-formed steel framing from 0.033 inch to 0.112 inch (1 mm to 3 mm) thick shall comply with ASTM C 955.

**R702.3.4 Insulating concrete form walls.** Foam plastics for insulating concrete form walls constructed in accordance with Sections R404.1.2 and R611 on the interior of habitable spaces shall be protected in accordance with Section R316.4. Use of adhesives in conjunction with mechanical fasteners is permitted. Adhesives used for interior and exterior finishes shall be compatible with the insulating form materials.

**R702.3.5 Application.** Maximum spacing of supports and the size and spacing of fasteners used to attach gypsum board shall comply with Table R702.3.5. Gypsum sheathing shall be attached to exterior walls in accordance with the standards used for the design of the building as specified in Section R301.2.1.1. Gypsum board shall be applied at right angles or parallel to framing members. All edges and ends of gypsum board shall occur on the framing members, except those edges and ends that are perpendicular to the framing members. Interior gypsum board shall not be installed where it is directly exposed to the weather or to water.

**R702.3.6 Fastening.** Screws for attaching gypsum board to wood framing shall be Type W or Type S in accordance with ASTM C 1002 and shall penetrate the wood not less than  $\frac{5}{8}$  inch (16 mm). Gypsum board shall be attached to cold-formed steel framing with minimum No. 6 screws. Screws for attaching gypsum board to cold-formed steel framing less than 0.033 inch (1 mm) thick shall be Type S in accordance with ASTM C 1002 or bugle head style in accordance with ASTM C 1513 and shall penetrate the steel not less than  $\frac{3}{8}$  inch (9.5 mm). Screws for attaching gypsum board to cold-formed steel framing 0.033 inch to 0.112 inch (1 mm to 3 mm) thick shall be in accordance with ASTM C 954 or bugle head style in accordance with ASTM C 1513. Screws for attaching gypsum board to structural insulated panels shall penetrate the wood structural panel facing not less than  $\frac{7}{16}$  inch (11 mm).

**R702.3.7 Horizontal gypsum board diaphragm ceilings.** Use of gypsum board shall be permitted on wood joists to create a horizontal *diaphragm* in accordance with Table R702.3.7. Gypsum board shall be installed perpendicular to ceiling framing members. End joints of adjacent courses of

board shall not occur on the same joist. The maximum allowable *diaphragm* proportions shall be 1½:1 between shear resisting elements. Rotation or cantilever conditions shall not be permitted. Gypsum board shall not be used in *diaphragm* ceilings to resist lateral forces imposed by masonry or concrete construction. All perimeter edges shall be blocked using wood members not less than 2-inch (51 mm) by 6-inch (152 mm) nominal dimension. Blocking material shall be installed flat over the top plate of the wall to provide a nailing surface not less than 2 inches (51 mm) in width for the attachment of the gypsum board.

**R702.3.8 Water-resistant gypsum backing board.** Gypsum board used as the base or backer for adhesive application of ceramic tile or other required nonabsorbent finish material shall conform to ASTM C 1396, C 1178 or C1278. Use of water-resistant gypsum backing board shall be permitted on ceilings where framing spacing does not exceed 12 inches (305 mm) on center for ½-inch-thick (12.7 mm) or 16 inches (406 mm) for 5/8-inch-thick (16 mm) gypsum board. Water-resistant gypsum board shall not be installed over a Class I or II vapor retarder in a shower or tub compartment. Cut or exposed edges, including those at wall intersections, shall be sealed as recommended by the manufacturer.

**R702.3.8.1 Limitations.** Water resistant gypsum backing board shall not be used where there will be direct exposure to water, or in areas subject to continuous high humidity.

**R702.4 Ceramic tile.**

**R702.4.1 General.** Ceramic tile surfaces shall be installed in accordance with ANSI A108.1, A108.4, A108.5, A108.6, A108.11, A118.1, A118.3, A136.1 and A137.1.

**R702.4.2 Fiber-cement, fiber-mat reinforced cement, glass mat gypsum backers and fiber-reinforced gypsum backers.** Fiber-cement, fiber-mat reinforced cement, glass mat gypsum backers or fiber-reinforced gypsum backers in compliance with ASTM C 1288, C 1325, C 1178 or C 1278, respectively, and installed in accordance with manufactur-

ers' recommendations shall be used as backers for wall tile in tub and shower areas and wall panels in shower areas.

**R702.5 Other finishes.** Wood veneer paneling and hardboard paneling shall be placed on wood or cold-formed steel framing spaced not more than 16 inches (406 mm) on center. Wood veneer and hard board paneling less than ¼ inch (6 mm) nominal thickness shall not have less than 3/8-inch (10 mm) gypsum board backer. Wood veneer paneling not less than ¼-inch (6 mm) nominal thickness shall conform to ANSI/HPVA HP-1. Hardboard paneling shall conform to CPA/ANSI A135.5.

**R702.6 Wood shakes and shingles.** Wood shakes and shingles shall conform to CSSB *Grading Rules for Wood Shakes and Shingles* and shall be permitted to be installed directly to the studs with maximum 24 inches (610 mm) on-center spacing.

**R702.6.1 Attachment.** Nails, staples or glue are permitted for attaching shakes or shingles to the wall, and attachment of the shakes or shingles directly to the surface shall be permitted provided the fasteners are appropriate for the type of wall surface material. When nails or staples are used, two fasteners shall be provided and shall be placed so that they are covered by the course above.

**R702.6.2 Furring strips.** Where furring strips are used, they shall be 1 inch by 2 inches or 1 inch by 3 inches (25 mm by 51 mm or 25 mm by 76 mm), spaced a distance on center equal to the desired exposure, and shall be attached to the wall by nailing through other wall material into the studs.

**SECTION R703  
EXTERIOR COVERING**

**R703.1 General.** Exterior walls shall provide the building with a weather-resistant exterior wall envelope. The exterior wall envelope shall include flashing as described in Section R703.8.

**R703.1.1 Water resistance.** The exterior wall envelope shall be designed and constructed in a manner that prevents the accumulation of water within the wall assembly by providing a water-resistant barrier behind the exterior veneer as

**TABLE R702.3.7  
SHEAR CAPACITY FOR HORIZONTAL WOOD-FRAMED  
GYPSUM BOARD DIAPHRAGM CEILING ASSEMBLIES**

MATERIAL	THICKNESS OF MATERIAL (min.) (in.)	SPACING OF FRAMING MEMBERS (max.) (in.)	SHEAR VALUE <sup>a, b</sup> (plf of ceiling)	MINIMUM FASTENER SIZE <sup>c, d</sup>
Gypsum board	½	16 o.c.	90	5d cooler or wallboard nail; 1 3/8-inch long; 0.086-inch shank; 15/64-inch head
Gypsum board	½	24 o.c.	70	5d cooler or wallboard nail; 1 3/8-inch long; 0.086-inch shank; 15/64-inch head

For SI: 1 inch = 25.4 mm, 1 pound per linear foot = 1.488 kg/m.

- a. Values are not cumulative with other horizontal diaphragm values and are for short-term loading caused by wind or seismic loading. Values shall be reduced 25 percent for normal loading.
- b. Values shall be reduced 50 percent in Seismic Design Categories D<sub>0</sub>, D<sub>1</sub>, D<sub>2</sub> and E.
- c. 1 ¼", #6 Type S or W screws may be substituted for the listed nails.
- d. Fasteners shall be spaced not more than 7 inches on center at all supports, including perimeter blocking, and not less than 3/8 inch from the edges and ends of the gypsum board.



required by Section R703.2 and a means of draining to the exterior water that enters the assembly. Protection against condensation in the exterior wall assembly shall be provided in accordance with Section R601.3 of this code.

**Exceptions:**

1. A weather-resistant exterior wall envelope shall not be required over concrete or masonry walls designed in accordance with Chapter 6 and flashed according to Section R703.7 or R703.8.
2. Compliance with the requirements for a means of drainage, and the requirements of Section R703.2 and Section R703.8, shall not be required for an exterior wall envelope that has been demonstrated to resist wind-driven rain through testing of the exterior wall envelope, including joints, penetrations and intersections with dissimilar materials, in accordance with ASTM E 331 under the following conditions:
  - 2.1. Exterior wall envelope test assemblies shall include at least one opening, one control joint, one wall/eave interface and one wall sill. All tested openings and penetrations shall be representative of the intended end-use configuration.
  - 2.2. Exterior wall envelope test assemblies shall be at least 4 feet (1219 mm) by 8 feet (2438 mm) in size.
  - 2.3. Exterior wall assemblies shall be tested at a minimum differential pressure of 6.24 pounds per square foot (299 Pa).
  - 2.4. Exterior wall envelope assemblies shall be subjected to the minimum test exposure for a minimum of 2 hours.

The exterior wall envelope design shall be considered to resist wind-driven rain where the results of testing indicate that water did not penetrate control joints in the exterior wall envelope, joints at the perimeter of openings penetration or intersections of terminations with dissimilar materials.

**703.1.2 Wind resistance.** Wall coverings, backing materials and their attachments shall be capable of resisting wind loads in accordance with Tables R301.2(2) and R301.2(3). Wind-pressure resistance of the siding and backing materials shall be determined by ASTM E 330 or other applicable standard test methods. Where wind-pressure resistance is determined by design analysis, data from approved design standards and analysis conforming to generally accepted engineering practice shall be used to evaluate the siding and backing material and its fastening. All applicable failure modes including bending rupture of siding, fastener withdrawal and fastener head pull-through shall be considered in

the testing or design analysis. Where the wall covering and the backing material resist wind load as an assembly, use of the design capacity of the assembly shall be permitted.

**R703.1.3 Load resistance.** All exterior walls, wall coverings and soffits shall be capable of resisting the design pressures specified in Table R301.2(2) for walls. Manufactured soffits shall be labeled in accordance with Section R616 of this code.

**R703.2 Weather-resistant sheathing paper.** One layer of No. 15 asphalt felt, free from holes and breaks, complying with ASTM D 226 for Type 1 felt or other approved water-resistive barrier shall be applied over studs or sheathing of all exterior walls. Such felt or material shall be applied horizontally, with the upper layer lapped over the lower layer not less than 2 inches (51 mm). Where joints occur, felt shall be lapped not less than 6 inches (152 mm). The felt or other approved material shall be continuous to the top of walls and terminated at penetrations and building appendages in a manner to meet the requirements of the exterior wall envelope as described in Section R703.1.

**Exception:** Omission of the water-resistive barrier is permitted in the following situations:

1. In detached accessory buildings.
2. Under exterior wall finish materials as permitted in Table R703.4.

**R703.3 Wood, hardboard and wood structural panel siding.**

**R703.3.1 Panel siding.** Joints in wood, hardboard or wood structural panel siding shall be made as follows unless otherwise approved. Vertical joints in panel siding shall occur over framing members, unless wood or wood structural panel sheathing is used, and shall be shiplapped or covered with a batten. Horizontal joints in panel siding shall be lapped a minimum of 1 inch (25 mm) or shall be shiplapped or shall be flashed with Z-flashing and occur over solid blocking, wood or wood structural panel sheathing.

**R703.3.2 Horizontal siding.** Horizontal lap siding shall be installed in accordance with the manufacturer's recommendations. Where there are no recommendations the siding shall be lapped a minimum of 1 inch (25 mm), or 1/2 inch (13 mm) if rabbeted, and shall have the ends caulked, covered with a batten or sealed and installed over a strip of flashing.

**R703.3.3 Attachment.** Wood, hardboard and wood structural panel siding shall be attached in accordance with Tables R703.3.3(1) and R703.3.3(2). Specific gravities, G for solid sawn lumber are specified in Table 703.3.3(3).

**R703.3.4 Minimum thickness.** Wood, hardboard and wood structural panel siding shall be of the minimum thickness specified in Tables R703.3.4(1) and R703.3.4(2).

**TABLE R703.3.3(1)  
WOOD, HARDBOARD AND WOOD STRUCTURAL PANEL SIDING ATTACHMENT EXPOSURE CATEGORY B**

	Maximum $V_{asd}$ as determined in accordance with Section R301.2.1.3	100		110		120		130		140		150	
		Structural Panel Siding											
		E	E	F	E	F	E	F	E	F	E	E	F
Siding Location	Stud Spacing (inches o.c.)	Nail Spacing for 8d Common Nails or 10d Box nails (inches o.c.)											
Interior Zone	12	6	12	6	12	6	12	6	12	6	12	6	12
	16	6	12	6	12	6	12	6	12	6	12	6	12
	24	6	12	6	12	6	12	6	12 <sup>2</sup>	6	12 <sup>2</sup>	6	12 <sup>2</sup>
Perimeter Edge Zone	12	6	12	6	12	6	12	6	12	6	12	6	12
	16	6	12	6	12	6	12	6	12	6	12	6	12 <sup>2</sup>
	24	6	12	6	12	6	12 <sup>2</sup>	6	12 <sup>2</sup>	6	12 <sup>2</sup>	6	12 <sup>2</sup>
		Board or Lap Siding											
Siding Size	Stud Spacing (inches o.c.)	Number of 8d Common Nails or 10d Box Nails Per Support											
1 x 6 or 1 x 8 Siding	12-24	2		2		2		2		2		2	
1 x 10 or Larger Siding	12-24	3		3		3		3		3		3	

**Notes:**

E – Nail spacing at panel edges (inches).

F – Nail spacing at intermediate supports (inches).

1. For wall siding within 4 feet of any corner, the 4-foot perimeter edge zone attachment requirements shall be used.

2. Tabulated 12-inch o.c. nail spacing assumes siding attached to stud framing members with a specific gravity,  $G \geq 0.49$ . For framing members with  $0.42 \leq G < 0.49$ , the nail spacings shall be reduced to 6 inches o.c.

3. For exterior panel siding, galvanized box nails shall be permitted to be substituted for common nails.

**TABLE R703.3.3(2)**  
**WOOD, HARDBOARD AND WOOD STRUCTURAL PANEL SIDING ATTACHMENT EXPOSURE CATEGORY C**

	Maximum $V_{asd}$ as determined in accordance with Section R301.2.1.3	100		110		120		130		140		150	
		<b>Structural Siding</b>											
		E	E	F	E	F	E	F	E	F	E	E	F
Siding Location	Stud Spacing (inches (o.c.))	<b>Nail Spacing for 8d Common Nails or 10d Box nails (inches o.c.)</b>											
		Interior Zone	12	6	12	6	12	6	12	6	12	6	12
16	6		12	6	12	6	12	6	12	6	12 <sup>2</sup>	6	12 <sup>2</sup>
24	6		12	6	12 <sup>2</sup>	6	12 <sup>2</sup>	6	12 <sup>2</sup>	6	6	6	6
Perimeter Edge Zone	12	6	12	6	12	6	12	6	12	6	12 <sup>2</sup>	6	12 <sup>2</sup>
	16	6	12	6	12	6	12	6	12 <sup>2</sup>	6	12 <sup>2</sup>	6	6
	24	6	12 <sup>2</sup>	6	12 <sup>2</sup>	6	6	6	6	6 <sup>3</sup>	6 <sup>3</sup>	6 <sup>3</sup>	6 <sup>3</sup>
		<b>Board or Lap Siding</b>											
Siding Size	Stud Spacing (inches o.c.)	<b>Number of 8d Common Nails or 10d Box Nails Per Support</b>											
		1 x 6 or 1 x 8 Siding	12-24	2	2	2	2	2	2	2	2	2	2
1 x 10 or Larger Siding	12-24	3	3	3	3	3	3	3	3	3	3	3	3

**Notes:**

E – Nail spacing at panel edges (inches).

F – Nail spacing at intermediate supports (inches).

- For wall siding within 4 feet of any corner, the 4-foot perimeter edge zone attachment requirements shall be used.
- Tabulated 12-inch o.c. nail spacing assumes siding attached to stud framing members with a specific gravity,  $G \geq 0.49$ . For framing members with  $0.42 \leq G < 0.49$ , the nail spacings shall be reduced to 6 inches o.c.
- Tabulated 6-inch o.c. nail spacing assumes siding attached to stud framing members with a specific gravity,  $G \geq 0.49$ . For framing members with  $0.42 \leq G < 0.49$ , the nail spacings shall be reduced to 4 inches o.c.
- For exterior panel siding, galvanized box nails shall be permitted to be substituted for common nails.

**TABLE R703.3.3(3)**  
**SPECIFIC GRAVITIES OF SOLID SAWN LUMBER**

Species Combination	Specific Gravity <sup>1</sup> , G	Species Combination	Specific Gravity <sup>1</sup> , G
Aspen	0.39	Mountain Hemlock	0.47
Balsam Fir	0.36	Northern Pine	0.42
Beech-Birch-Hickory	0.71	Northern Red Oak	0.68
Coast Sitka Spruce	0.39	Northern Species	0.35
Cottonwood	0.41	Northern White Cedar	0.31
Douglas Fir-Larch	0.50	Ponderosa Pine	0.43
Douglas Fir-Larch (North)	0.49	Red Maple	0.58
Douglas Fir-South	0.46	Red Oak	0.67
Eastern Hemlock	0.41	Red Pine	0.44
Eastern Hemlock-Balsam Fir	0.36	Redwood, close grain	0.44
Eastern Hemlock-Tamarack	0.41	Redwood, open grain	0.37
Eastern Hemlock-Tamarack (North)	0.47	Sitka Spruce	0.43
Eastern Softwoods	0.36		
Eastern Spruce	0.41	Southern Pine	0.55
Eastern White Pine	0.36	Spruce-Pine-Fir	0.42
Engelmann Spruce-Lodgepole Pine	0.38	Spruce-Pine-Fir	0.50
Engelmann Spruce-Lodgepole Pine <sup>2</sup> (MSR 1650f and higher grades)	0.46	(E > 2,000,000 psi MSR and MEL)	
Engelmann Spruce-Lodgepole Pine <sup>2</sup> (MSR 1500f and lower grades)	0.38	Spruce-Pine-Fir (South)	0.36
		Western Cedars	0.36
		Western Cedars (North)	0.35
		Western Hemlock	0.47
Hem-Fir	0.43	Western Hemlock (North)	0.46
Hem-Fir (North)	0.46	Western White Pine	0.40
Mixed Maple	0.55	Western Woods	0.36
Mixed Oak	0.68	White Oak	0.73
Mixed Southern Pine	0.51	Yellow Poplar	0.43

<sup>1</sup>Specific gravity based on weight and volume when oven-dry.

<sup>2</sup>Applies only to Engelmann Spruce-Lodgepole Pine machine stress rated (MSR) structural lumber



**TABLE R703.3.4(1)**  
**WOOD, HARDBOARD AND WOOD STRUCTURAL PANEL SIDING MINIMUM THICKNESS**  
**EXPOSURE CATEGORY B**

Maximum $V_{asd}$ as determined in accordance with Section R301.2.1.3	100	110	120	130	140	150
	<b>Wood Structural Panel Siding and Hardboard Panel Siding (Short dimension across studs)</b>					
<b>Stud Spacing (inches (o.c.))</b>	<b>Minimum Panel Thickness (in.)</b>					
12	$\frac{3}{8}$	$\frac{3}{8}$	$\frac{3}{8}$	$\frac{3}{8}$	$\frac{3}{8}$	$\frac{3}{8}$
16	$\frac{3}{8}$	$\frac{3}{8}$	$\frac{3}{8}$	$\frac{7}{16}$	$\frac{15}{32}$	$\frac{15}{32}$
24	$\frac{15}{32}$	$\frac{15}{32}$	$\frac{19}{32}$	$\frac{19}{32}$	$\frac{19}{32}$	$\frac{23}{32}$
	<b>Board and Hardboard Lap Siding (diagonal across three or more supports)</b>					
<b>Stud Spacing (inches o.c.)</b>	<b>Minimum Panel Thickness (in.)</b>					
12-16	$\frac{7}{16}$	$\frac{7}{16}$	$\frac{7}{16}$	$\frac{7}{16}$	$\frac{7}{16}$	$\frac{7}{16}$

**TABLE R703.3.4(2)**  
**WOOD, HARDBOARD AND WOOD STRUCTURAL PANEL SIDING MINIMUM THICKNESS**  
**EXPOSURE CATEGORY C**

Maximum $V_{asd}$ as determined in accordance with Section R301.2.1.3	100	110	120	130	140	150
	<b>Wood Structural Panel Siding and Hardboard Panel Siding (Short dimension across studs)</b>					
<b>Stud Spacing (inches (o.c.))</b>	<b>Minimum Panel Thickness (in.)</b>					
12	$\frac{3}{8}$	$\frac{3}{8}$	$\frac{3}{8}$	$\frac{3}{8}$	$\frac{3}{8}$	$\frac{7}{16}$
16	$\frac{3}{8}$	$\frac{7}{16}$	$\frac{15}{32}$	$\frac{15}{32}$	$\frac{15}{32}$	$\frac{19}{32}$
24	$\frac{19}{32}$	$\frac{19}{32}$	$\frac{19}{32}$	$\frac{23}{32}$	$\frac{23}{32}$	—
	<b>Board and Hardboard Lap Siding (diagonal across three or more supports)</b>					
<b>Stud Spacing (inches o.c.)</b>	<b>Minimum Panel Thickness (in.)</b>					
12-16	$\frac{7}{16}$	$\frac{7}{16}$	$\frac{7}{16}$	$\frac{7}{16}$	$\frac{7}{16}$	$\frac{7}{16}$

**R703.4 Attachments.** Unless specified otherwise, all wall coverings shall be secured with approved aluminum, stainless steel, zinc-coated or other approved corrosion-resistive fasteners in accordance with the approved manufacturer's installation instructions. Where wind pressures determined in accordance with Table R301.2(2) do not exceed 50 psf, wall coverings are permitted to be installed in accordance with Table R703.4.

**R703.5 Wood shakes and shingles.** Wood shakes and shingles shall conform to CSSB *Grading Rules for Wood Shakes and Shingles*.

**R703.5.1 Application.** Wood shakes or shingles shall be applied either single-course or double-course over nominal  $\frac{1}{2}$ -inch (13 mm) wood-based sheathing or to furring strips over  $\frac{1}{2}$ -inch (13 mm) nominal nonwood sheathing. A permeable water-resistive barrier shall be provided over all sheathing, with horizontal overlaps in the membrane of not less than 2 inches (51mm) and vertical overlaps of not less than 6 inches (152 mm). Where furring strips are used, they shall be 1 inch by 3 inches or 1 inch by 4 inches (25 mm by 76 mm or 25 mm by 102 mm) and shall be fastened horizontally to the studs with 7d or 8d box nails and shall be spaced a dis-

tance on center equal to the actual weather exposure of the shakes or shingles, not to exceed the maximum exposure specified in Table R703.5.2. The spacing between adjacent shingles to allow for expansion shall not exceed  $\frac{1}{4}$  inch (6 mm), and between adjacent shakes, it shall not exceed  $\frac{1}{2}$  inch (13 mm). The offset spacing between joints in adjacent courses shall be a minimum of  $1\frac{1}{2}$  inches (38 mm).

**R703.5.2 Weather exposure.** The maximum weather exposure for shakes and shingles shall not exceed that specified in Table R703.5.2.

**R703.5.3 Attachment.** Wood shakes and shingles, and attachment and supports shall be capable of resisting the wind pressures determined in accordance with Table R310.2(2). Where wind pressures determined in accordance with Table R301.2(2) do not exceed 30 psf, each shake or shingle shall be held in place by two hot-dipped zinc-coated, stainless steel, or aluminum nails. The fasteners shall be long enough to penetrate the sheathing or furring strips by a minimum of  $\frac{1}{2}$  inch (12.7 mm) and shall not be overdriven. Where pressures determined in accordance with Table R301.2(2) exceed 30 psf, the attachment shall be designed to resist the prescribed wind pressures.

**TABLE R703.4  
WEATHER-RESISTANT SIDING ATTACHMENT AND MINIMUM THICKNESS**

SIDING MATERIAL	NOMINAL THICKNESS <sup>a</sup> (inches)	JOINT TREATMENT	WATER-RESISTIVE BARRIER REQUIRED	TYPE OF SUPPORTS FOR THE SIDING MATERIAL AND FASTENERS <sup>b, c, d</sup>					Number or spacing of fasteners	
				Wood or wood structural panel sheathing	Fiberboard sheathing into stud	Gypsum sheathing into stud	Foam plastic sheathing into stud	Direct to studs		
Horizontal aluminum <sup>e</sup>	Without insulation	0.019 <sup>f</sup>	Lap	Yes	0.120 nail 1 1/2" long	0.120 nail 2" long	0.120 nail 2" long	0.120 nail <sup>g</sup>	Not allowed	Same as stud spacing
		0.024	Lap	Yes	0.120 nail 1 1/2" long	0.120 nail 2" long	0.120 nail 2" long	0.120 nail <sup>g</sup>	Not allowed	
	With insulation	0.019	Lap	Yes	0.120 nail 1 1/2" long	0.120 nail 2 1/2" long	0.120 nail 2 1/2" long	0.120 nail <sup>g</sup>	0.120 nail 1 1/2" long	
Anchored veneer: brick, concrete, masonry or stone	2	Section R703	Yes	See Section R703 and Figure R703.7 <sup>h</sup>						
Adhered veneer: concrete, stone or masonry <sup>h</sup>	—	Section R703	Yes Note w	See Section R703.6.1 <sup>h</sup> or in accordance with the manufacturer's instructions.						
Hardboard <sup>k</sup> Panel siding-vertical	See Section R703.3.4	—	Yes	See Section R703.3.4						
Hardboard <sup>k</sup> Lap-siding-horizontal	See Section R703.3.4	Note p	Yes	See Section R703.3.4						
Steel <sup>h</sup>	29 ga.	Lap	Yes	0.113 nail 1 3/4"	0.113 nail 2 3/4"	0.113 nail 2 1/2"	0.113 nail <sup>v</sup>	Not allowed	Same as stud spacing	
Wood structural panel siding <sup>i</sup> (exterior grade)	3/8 - 1/2	Note p	Yes	0.099 nail-2"	0.113 nail-2 1/2"	0.113 nail-2 1/2"	0.113 nail <sup>v</sup>	0.099 nail-2"	6" panel edges, 12" inter. sup.	
Wood structural panel lapsiding	3/8 - 1/2	Note p Note x	Yes	0.099 nail-2"	0.113 nail-2 1/2"	0.113 nail-2 1/2"	0.113 nail <sup>s</sup>	0.099 nail-2"	8" along bottom edge	
Vinyl siding <sup>l</sup>	0.035	Lap	Yes	See Section R703.11						
Wood rustic, drop	3/8 Min	Lap	Yes	Fastener penetration into stud-1"					0.113 nail-2 1/2"	Face nailing up to 6" widths, 1 nail per bearing; 8" widths and over, 2 nails per bearing
Shiplap	19/32 Average	Lap	Yes							
Bevel	7/16	Lap	Yes							
Butt tip	3/16	Lap	Yes							
Fiber cement panel siding <sup>a</sup>	5/16	Note q	Yes Note u	6d common corrosion-resistant nail <sup>f</sup>	6d common corrosion-resistant nail <sup>f</sup>	6d common corrosion-resistant nail <sup>f</sup>	6d common corrosion-resistant nail <sup>r, v</sup>	4d common corrosion-resistant nail <sup>f</sup>	6" o.c. on edges, 12" o.c. on intermed. studs	
Fiber cement lap siding <sup>a</sup>	5/16	Note s	Yes Note u	6d common corrosion-resistant nail <sup>f</sup>	6d common corrosion-resistant nail <sup>f</sup>	6d common corrosion-resistant nail <sup>f</sup>	6d common corrosion-resistant nail <sup>r, v</sup>		Note t	

- For SI: 1 inch = 25.4 mm.
- a. Based on stud spacing of 16 inches on center where studs are spaced 24 inches, siding shall be applied to sheathing approved for that spacing.
  - b. Nail is a general description and shall be T-head, modified round head, or round head with smooth or deformed shanks.
  - c. Reserved.
  - d. Nails or staples shall be aluminum, galvanized, or rust-preventative coated and shall be driven into the studs for fiberboard or gypsum backing.
  - e. Aluminum nails shall be used to attach aluminum siding.
  - f. Aluminum (0.019 inch) shall be unbacked only when the maximum panel width is 10 inches and the maximum flat area is 8 inches. The tolerance for aluminum siding shall be +0.002 inch of the nominal dimension.
  - g. All attachments shall be coated with a corrosion-resistant coating.
  - h. Shall be of approved type.
  - i. Three-eighths-inch plywood shall not be applied directly to studs spaced more than 16 inches on center when long dimension is parallel to studs. Plywood 1/2-inch or thinner shall not be applied directly to studs spaced more than 24 inches on center. The stud spacing shall not exceed the panel span rating provided by the manufacturer unless the panels are installed with the face grain perpendicular to the studs or over sheathing approved for that stud spacing.
  - j. Wood board sidings applied vertically shall be nailed to horizontal nailing strips or blocking set 24 inches on center. Nails shall penetrate 1 1/2 inches into studs, studs and wood sheathing combined or blocking.
  - k. Hardboard siding shall comply with CPA/ANSI A135.6.
  - l. Vinyl siding shall comply with ASTM D 3679.
  - m. Reserved.
  - n. When used to resist shear forces, the spacing must be 4 inches at panel edges and 8 inches on interior supports.
  - o. Reserved.
  - p. Vertical end joints shall occur at studs and shall be covered with a joint cover or shall be caulked.
  - q. See Section R703.10.1.
  - r. Fasteners shall comply with the nominal dimensions in ASTM F 1667.
  - s. See Section R703.10.2.
  - t. Face nailing: one 6d common nail through the overlapping planks at each stud. Concealed nailing: one 11 gage 1 1/2 inch long galv. roofing nail through the top edge of each plank at each stud.
  - u. See Section R703.2 exceptions.
  - v. Minimum nail length must accommodate sheathing and penetrate framing 1 1/2 inches.
  - w. Adhered masonry veneer shall comply with the requirements of Section R703.6.3 and shall comply with the requirements in Sections 6.1 and 6.3 of TMS 402/ACI 530/ASCE 5.
  - x. Vertical joints, if staggered shall be permitted to be away from studs if applied over wood structural panel sheathing.
  - y. Minimum fastener length must accommodate sheathing and penetrate framing .75 inches or in accordance with the manufacturer's installation instructions.
  - z. Where approved by the manufacturer's instructions or test report siding shall be permitted to be installed with fasteners penetrating not less than .75 inches through wood or wood structural sheathing with or without penetration into the framing.

**TABLE R703.5.2**  
**MAXIMUM WEATHER EXPOSURE FOR WOOD SHAKES AND SHINGLES ON EXTERIOR WALLS<sup>a, b, c</sup>**  
 (Dimensions are in inches)

LENGTH	EXPOSURE FOR SINGLE COURSE	EXPOSURE FOR DOUBLE COURSE
Shingles <sup>a</sup>		
16	7 <sup>1</sup> / <sub>2</sub>	12 <sup>b</sup>
18	8 <sup>1</sup> / <sub>2</sub>	14 <sup>c</sup>
24	11 <sup>1</sup> / <sub>2</sub>	16
Shakes <sup>a</sup>		
18	8 <sup>1</sup> / <sub>2</sub>	14
24	11 <sup>1</sup> / <sub>2</sub>	18

For SI: 1 inch = 25.4 mm.

a. Dimensions given are for No. 1 grade.

b. A maximum 10-inch exposure is permitted for No. 2 grade.

c. A maximum 11-inch exposure is permitted for No. 2 grade.

**R703.5.3.1 Staple attachment.** Reserved.

**R703.5.4 Bottom courses.** The bottom courses shall be doubled.

### R703.6 Exterior plaster.

**R703.6.1** Exterior use of Portland cement plaster shall comply with the application requirements of ASTM C 926.

**R703.6.2** Installation of exterior lathing and framing shall comply with the application requirements of ASTM C 1063.

**R703.6.2.1 Weep screeds.** Reserved.

**R703.6.3** Where cement plaster (stucco) is to be applied to lath over frame construction, measures shall be taken to prevent bonding between the cement plaster and the water-resistive barrier. A bond break shall be provided between the water-resistive barrier and the cement plaster (stucco) consisting of one of the following:

1. Two layers of an approved water-resistant barrier material; or
2. One layer of an approved water-resistant barrier over an approved plastic house wrap; or
3. Other approved methods or materials applied in accordance with the manufacturer's installation instructions.

### R703.6.4 Pneumatically placed portland cement plaster.

**R703.6.4.1** Pneumatically placed portland cement plaster shall be a mixture of portland cement and aggregate conveyed by air through a pipe or flexible tube, and deposited by air pressure in its final position.

**R703.6.4.2** Rebound material may be screened and reused as aggregate in an amount not greater than 25 percent of the total sand in any batch.

**R703.6.4.3** Pneumatically placed portland cement plaster shall consist of a mixture of one part cement to not more than five parts of aggregate. Plasticity agents may be used as specified elsewhere in this chapter. Except when applied to concrete or masonry, such plaster shall be applied in not less than two coats to a minimum total thickness of <sup>7</sup>/<sub>8</sub> inch (22.2 mm).

**R703.6.5 Fenestration.** The juncture of exterior plaster and fenestration products shall be sealed with a sealant complying with Section R612.12.

**R703.7 Stone and masonry veneer, general.** All stone and masonry veneer shall be installed in accordance with this chapter, Table R703.4 and Figure R703.7. The provisions of this section are limited to areas where the  $V_{asd}$ , as determined in accordance with Section R301.2.1.3, is equal to or less than 130 mph.

**Exception:** For detached one- and two- family dwellings, exterior masonry veneer with a backing of wood or cold-formed steel framing shall not exceed 30 feet (9144 mm) in height above the noncombustible foundation, with an additional 8 feet (2348 mm) permitted for gabled ends.

**Table R703.7(1) Stone or Masonry Veneer Limitations and Requirements, Wood or Steel Framing, Seismic Design Categories A, B and C.** Reserved

**Table R703.7(2) Stone or Masonry Veneer Limitations and Requirements, One- and Two-Family Dwellings, Wood Framing, Seismic Design Categories D<sub>0</sub>, D<sub>1</sub> and D<sub>2</sub>.** Reserved

**R703.7.1 Interior veneer support.** Veneers used as interior wall finishes shall be permitted to be supported on wood or cold-formed steel floors that are designed to support the loads imposed.

**R703.7.2 Exterior veneer support.** Exterior masonry veneers having an installed weight of 40 pounds per square foot (195 kg/m<sup>2</sup>) or less shall be permitted to be supported on wood or cold-formed steel construction. When masonry veneer supported by wood or cold-formed steel construction adjoins masonry veneer supported by the foundation, there shall be a movement joint between the veneer supported by the wood or cold-formed steel construction and the veneer supported by the foundation. The wood or cold-formed steel construction supporting the masonry veneer shall be designed to limit the deflection to <sup>1</sup>/<sub>600</sub> of the span for the supporting members. The design of the wood or cold-formed steel construction shall consider the weight of the veneer and any other loads.

**R703.7.2.1 Support by steel angle.** A minimum 6 inches by 4 inches by <sup>5</sup>/<sub>16</sub> inch (152 mm by 102 mm by 8 mm)

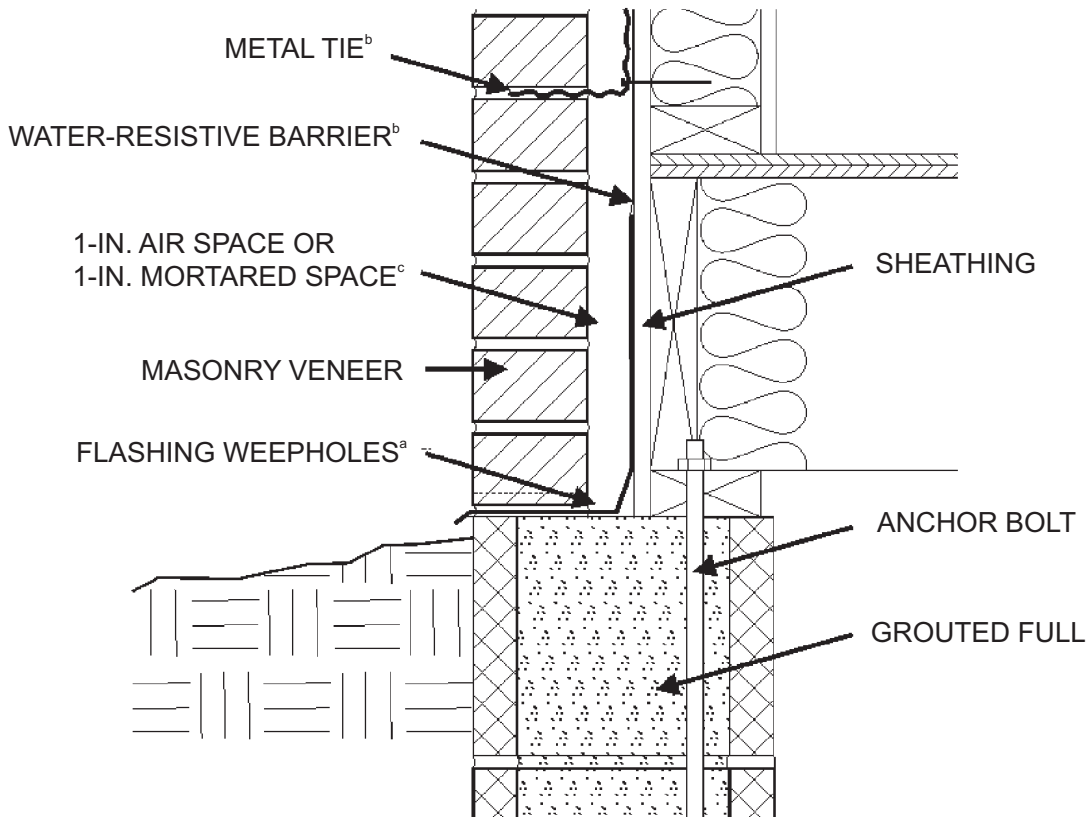
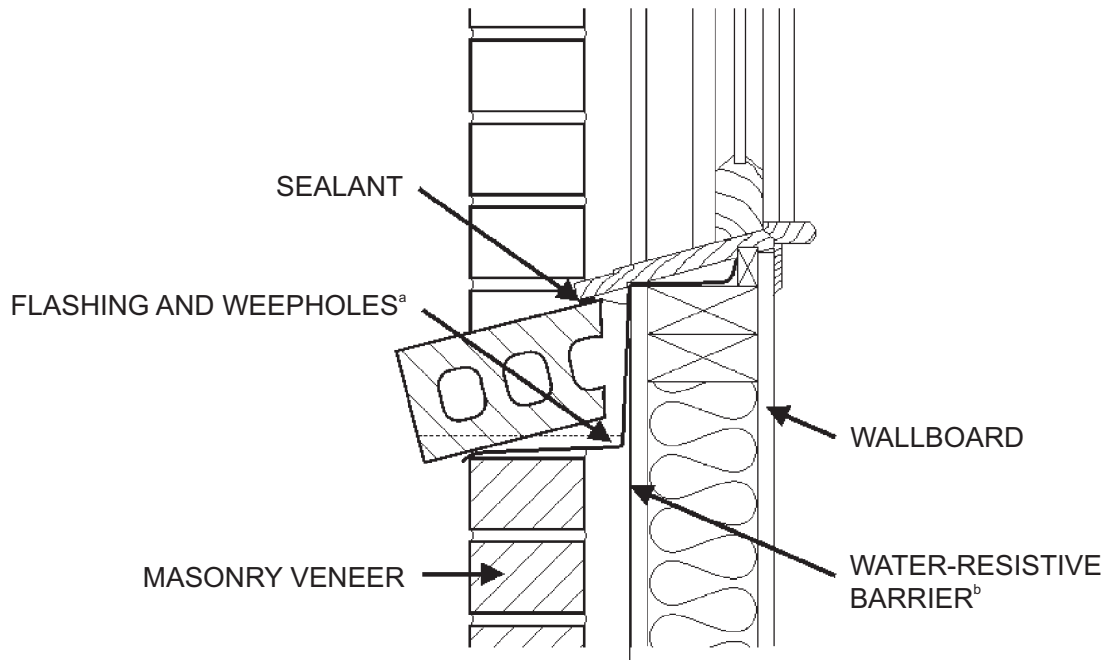

For SI: 1 inch = 25.4 mm.

**FIGURE R703.7**  
**MASONRY VENEER WALL DETAILS**  
*(continued)*

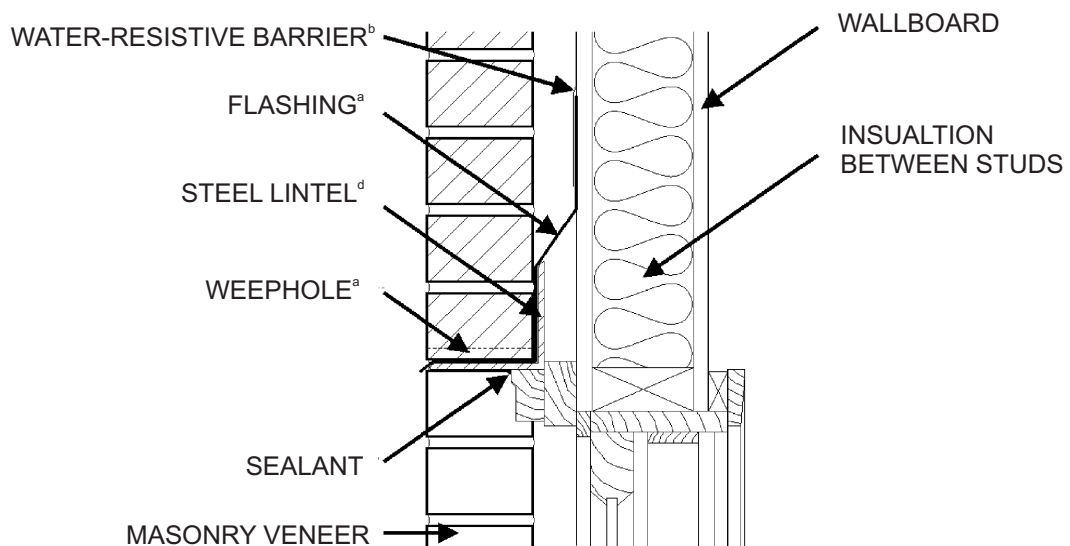
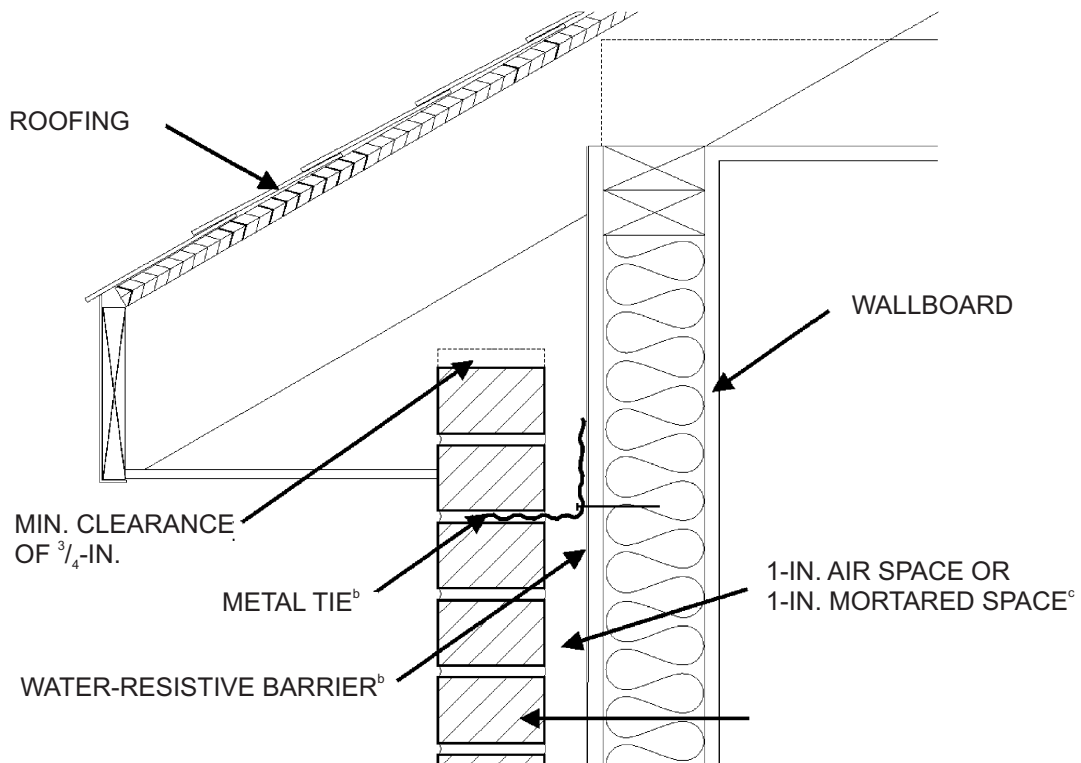

For SI: 1 inch = 25.4 mm.

a. See Sections R703.7.5, R703.7.6 and R703.8.

b. See Sections R703.2 and R703.7.4.

c. See Sections R703.7.4.2 and R703.7.4.3.

d. See Section R703.7.3.

**FIGURE R703.7—continued  
MASONRY VENEER WALL DETAILS**

steel angle, with the long leg placed vertically, shall be anchored to double 2 inches by 4 inches (51 mm by 102 mm) wood studs at a maximum on-center spacing of 16 inches (406 mm). Anchorage of the steel angle at every double stud spacing shall be a minimum of two  $\frac{7}{16}$  inch (11 mm) diameter by 4 inch (102 mm) lag screws. The steel angle shall have a minimum clearance to underlying construction of  $\frac{1}{16}$  inch (2 mm). A minimum of two-thirds the width of the masonry veneer thickness shall bear on the steel angle. Flashing and weep holes shall be located in the masonry veneer wythe in accordance with Figure R703.7.2.1. The maximum height of masonry veneer above the steel angle support shall be 12 feet, 8 inches (3861 mm). The air space separating the masonry veneer from the wood backing shall be in accordance with Sections R703.7.4 and R703.7.4.2. The method of support for the masonry veneer on wood construction shall be constructed in accordance with Figure R703.7.2.1.

The maximum slope of the roof construction without stops shall be 7:12. Roof construction with slopes greater than 7:12 but not more than 12:12 shall have stops of a minimum 3 inch  $\times$  3 inch  $\times$   $\frac{1}{4}$  inch (76 mm  $\times$  76 mm  $\times$  6 mm) steel plate welded to the angle at 24 inches (610 mm) on center along the angle or as *approved* by the *building official*.

**R703.7.2.2 Support by roof construction.** A steel angle shall be placed directly on top of the roof construction. The roof supporting construction for the steel angle shall consist of a minimum of three 2-inch by 6-inch (51 mm by 152 mm) wood members. The wood member abutting the vertical wall stud construction shall be anchored with a minimum of three  $\frac{5}{8}$ -inch (16 mm) diameter by 5-inch (127 mm) lag screws to every wood stud spacing. Each additional roof member shall be anchored by the use of two 10d nails at every wood stud spacing. A minimum of two-thirds the width of the masonry veneer thickness shall bear on the steel angle. Flashing and weep holes shall be located in the masonry veneer wythe in accordance with Figure R703.7.2.2. The maximum height of the masonry veneer above the steel angle support shall be 12 feet, 8 inches (3861 mm). The air space separating the masonry veneer from the wood backing shall be in accordance with Sections R703.7.4 and R703.7.4.2. The support for the masonry veneer on wood construction shall be constructed in accordance with Figure R703.7.2.2.

The maximum slope of the roof construction without stops shall be 7:12. Roof construction with slopes greater than 7:12 but not more than 12:12 shall have stops of a minimum 3 inch  $\times$  3 inch  $\times$   $\frac{1}{4}$  inch (76 mm  $\times$  76 mm  $\times$  6 mm) steel plate welded to the angle at 24 inches (610 mm)

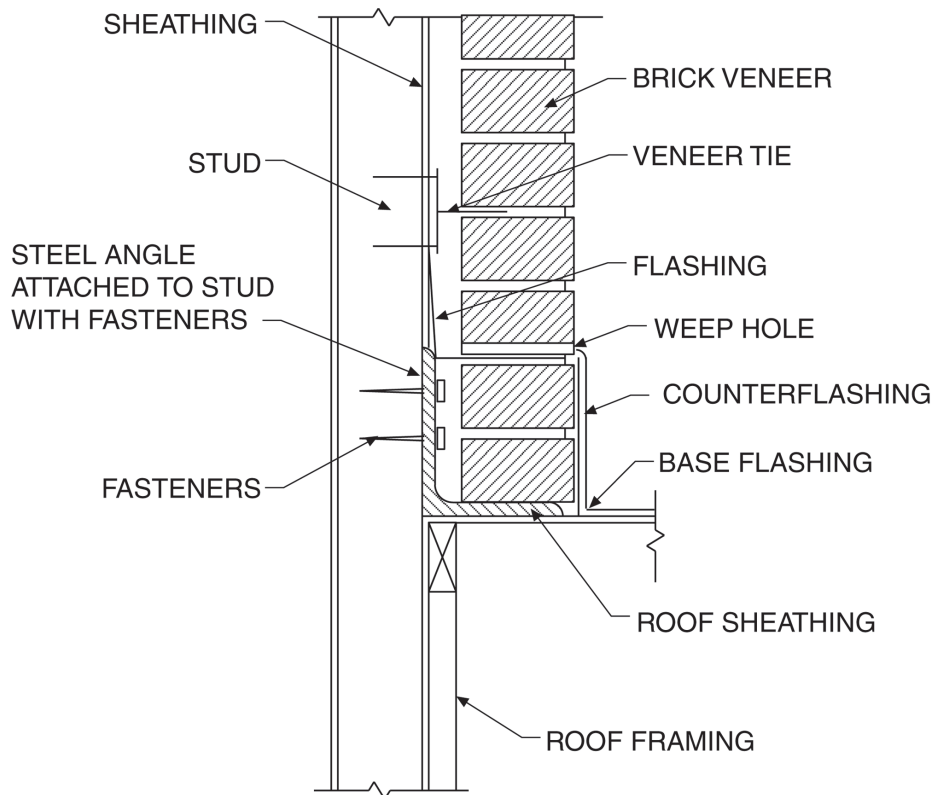

SUPPORT BY STEEL ANGLE

FIGURE R703.7.2.1  
EXTERIOR MASONRY VENEER SUPPORT BY STEEL ANGLES



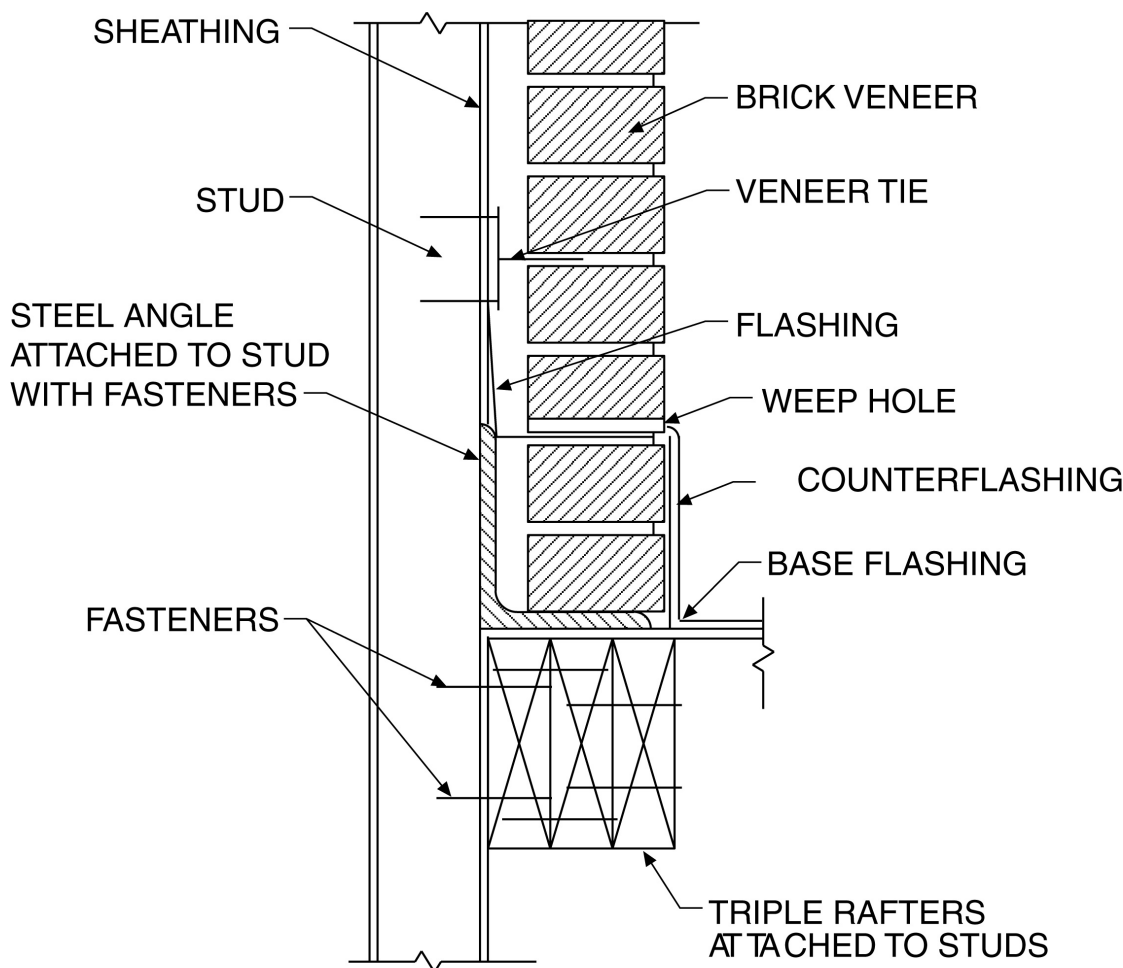

### SUPPORT BY ROOF MEMBERS

FIGURE R703.7.2.2  
EXTERIOR MASONRY VENEER SUPPORT BY ROOF MEMBERS

mm) on center along the angle or as *approved* by the *building official*.

**R703.7.3 Lintels.** Masonry veneer shall not support any vertical load other than the dead load of the veneer above. Veneer above openings shall be supported on lintels of noncombustible materials. The lintels shall have a length of bearing not less than 4 inches (102 mm). Steel lintels shall be shop coated with a rust-inhibitive paint, except for lintels made of corrosion-resistant steel or steel treated with coatings to provide corrosion resistance. Construction of openings shall comply with either Section R703.7.3.1 or 703.7.3.2.

**R703.7.3.1** The allowable span shall not exceed the values set forth in Table R703.7.3.1.

**R703.7.3.2** The allowable span shall not exceed 18 feet 3 inches (5562 mm) and shall be constructed to comply with Figure R703.7.3.2 and the following:

1. Provide a minimum length of 18 inches (457 mm) of masonry veneer on each side of opening as shown in Figure R703.7.3.2.
2. Provide a minimum 5 inch by 3½ inch by 5/16 inch (127 mm by 89 mm by 7.9 mm) steel angle above the opening and shore for a minimum of 7 days after installation.
3. Provide double-wire joint reinforcement extending 12 inches (305 mm) beyond each side of the opening. Lap splices of joint reinforcement a minimum of 12 inches (305 mm). Comply with one of the following:
  - 3.1. Double-wire joint reinforcement shall be 3/16 inch (4.8 mm) diameter and shall be placed in the first two bed joints above the opening.
  - 3.2. Double-wire joint reinforcement shall be 9 gauge (0.144 inch or 3.66 mm diameter)

**TABLE R703.7.3.1**  
**ALLOWABLE SPANS FOR LINTELS SUPPORTING MASONRY VENEER<sup>a, b, c, d</sup>**

SIZE OF STEEL ANGLE <sup>a, c, d</sup> (inches)	NO STORY ABOVE	ONE STORY ABOVE	TWO STORIES ABOVE	NO. OF 1/2" OR EQUIVALENT REINFORCING BARS IN REINFORCED LINTEL <sup>b, d</sup>
3 × 3 × 1/4	6'-0"	4'-6"	3'-0"	1
4 × 3 × 1/4	8'-0"	6'-0"	4'-6"	1
5 × 3 1/2 × 5/16	10'-0"	8'-0"	6'-0"	2
6 × 3 1/2 × 5/16	14'-0"	9'-6"	7'-0"	2
2-6 × 3 1/2 × 5/16	20'-0"	12'-0"	9'-6"	4

For SI: 1 inch = 25.4 mm, 1 foot = 304.8 mm.

- a. Long leg of the angle shall be placed in a vertical position.
- b. Depth of reinforced lintels shall not be less than 8 inches and all cells of hollow masonry lintels shall be grouted solid. Reinforcing bars shall extend not less than 8 inches into the support.
- c. Steel members indicated are adequate typical examples; other steel members meeting structural design requirements may be used.
- d. Either steel angle or reinforced lintel shall span opening.

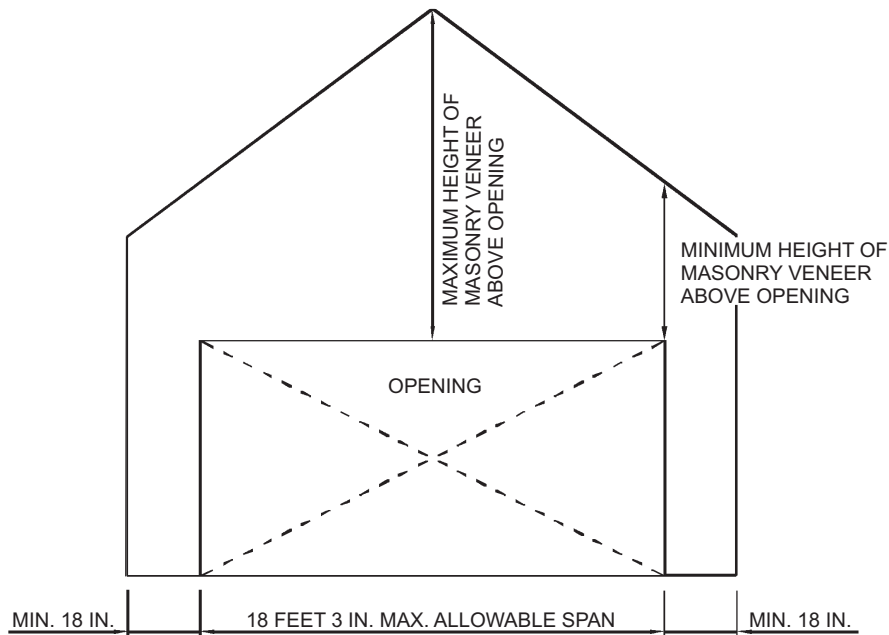

For SI: 1 inch = 25.4 mm, 1 foot = 304.8 mm.

**FIGURE R703.7.3.2**  
**MASONRY VENEER OPENING**

and shall be placed in the first three bed joints above the opening.

**R703.7.4 Anchorage.** Masonry veneer shall be anchored to the supporting wall with corrosion-resistant metal ties embedded in mortar or grout and extending into the veneer a minimum of 1 1/2 inches (38 mm), with not less than 5/8 inch (15.9 mm) mortar or grout cover to outside face. Where veneer is anchored to wood backings by corrugated sheet metal ties, the distance separating the veneer from the sheathing material shall be a maximum of a nominal 1 inch (25 mm). Where the veneer is anchored to wood backings using metal strand wire ties, the distance separating the

veneer from the sheathing material shall be a maximum of 4 1/2 inches (114 mm). Where the veneer is anchored to cold-formed steel backings, adjustable metal strand wire ties shall be used. Where veneer is anchored to cold-formed steel backings, the distance separating the veneer from the sheathing material shall be a maximum of 4 1/2 inches (114 mm).

**R703.7.4.1 Size and spacing.** Veneer ties, if strand wire, shall not be less in thickness than No. 9 U.S. gage [(0.148 in.) (4 mm)] wire and shall have a hook embedded in the mortar joint, or if sheet metal, shall be not less than No.

22 U.S. gage by [(0.0299 in.) (0.76 mm)]  $\frac{7}{8}$  inch (22 mm) corrugated. Each tie shall be spaced not more than 24 inches (610 mm) on center horizontally and vertically and shall support not more than 2.67 square feet (0.25 m<sup>2</sup>) of wall area.

**Exception:** Where the  $V_{asd}$  as determined in accordance with Section R301.2.1.3 exceeds 110 mph (176.99 km/h) or is less than or equal to 130 mph (208 km/h), each tie shall support not more than 1.8 square feet (0.167 m<sup>2</sup>) of wall area and anchors shall be spaced at a maximum 18 inches (457 mm) horizontally and vertically.

**R703.7.4.1 Veneer ties around wall openings.** Veneer ties around wall openings. Additional metal ties shall be provided around all wall openings greater than 16 inches (406 mm) in either dimension. Metal ties around the perimeter of openings shall be spaced not more than 3 feet (914 mm) on center and placed within 12 inches (305 mm) of the wall opening.

**R703.7.4.2 Air space.** The veneer shall be separated from the sheathing by an air space of a minimum of a nominal 1 inch (25 mm) but not more than 4 $\frac{1}{2}$  inches (114 mm).

**Exception:** Where the wind pressure determined in accordance with Table R301.2(2) exceeds 30 pounds per square foot pressure (1.44 kN/m<sup>2</sup>), the air space shall not exceed 2 inches (51 mm).

**R703.7.4.3 Mortar or grout fill.** As an alternate to the air space required by Section R703.7.4.2, mortar or grout shall be permitted to fill the air space. When the air space is filled with mortar, a water-resistive barrier is required over studs or sheathing. When filling the air space, replacing the sheathing and water-resistive barrier with a wire mesh and *approved* water-resistive barrier or an *approved* water-resistive barrier-backed reinforcement attached directly to the studs is permitted.

**R703.7.5 Flashing.** Flashing shall be located beneath the first course of masonry above finished ground level above the foundation wall or slab and at other points of support, including structural floors, shelf angles and lintels when masonry veneers are designed in accordance with Section R703.7. See Section R703.8 for additional requirements.

**R703.7.6 Weepholes.** Weepholes shall be provided in the outside wythe of masonry walls at a maximum spacing of 33 inches (838 mm) on center. Weepholes shall not be less than  $\frac{3}{16}$  inch (5 mm) in diameter. Weepholes shall be located immediately above the flashing.

**R703.8 Flashing.** *Approved* corrosion-resistant flashing shall be applied shingle-fashion in a manner to prevent entry of water into the wall cavity or penetration of water to the building structural framing components. Self-adhered membranes used as flashing shall comply with AAMA 711. The flashing shall extend to the surface of the exterior wall finish. *Approved* corrosion-resistant flashings shall be installed at all of the following locations:

1. Exterior window and door openings. Flashing at exterior window and door openings shall extend to the surface of

the exterior wall finish or to the water-resistive barrier for subsequent drainage. Flashing at exterior window and door openings shall be installed in accordance with one or more of the following or other approved method:

- 1.1 The fenestration manufacturer's written flashing instructions.
- 1.2 The flashing manufacturer's written installation instructions.
- 1.3 In accordance with FMA/AAMA 100, FMA/AAMA 200, or FMA/WDMA 250.
- 1.4 In accordance with the flashing method of a registered design professional.
2. At the intersection of chimneys or other masonry construction with frame or stucco walls, with projecting lips on both sides under stucco copings.
3. Under and at the ends of masonry, wood or metal copings and sills.
4. Continuously above all projecting wood trim.
5. Where exterior porches, decks or stairs attach to a wall or floor assembly of wood-frame construction.
6. At wall and roof intersections.
7. At built-in gutters.

**R703.9 Exterior insulation and finish system (EIFS)/EIFS with drainage.** Exterior Insulation and Finish System (EIFS) shall be designed or tested to meet the wind pressures specified in Table R301.2(2) and shall comply with this chapter and Sections R703.9.1 and R703.9.3. EIFS with drainage shall comply with this chapter and Sections R703.9.2, R703.9.3 and R703.9.4.

**R703.9.1 Exterior insulation and finish system (EIFS).** EIFS shall comply with ASTM E 2568.

**R703.9.2 Exterior insulation and finish system (EIFS) with drainage.** EIFS with drainage shall comply with ASTM E 2568 and shall have an average minimum drainage efficiency of 90 percent when tested in accordance with ASTM E 2273.

**R703.9.2.1 Water-resistive barrier.** The water-resistive barrier shall comply with Section R703.2 or ASTM E 2570.

**R703.9.2.2 Installation.** The water-resistive barrier shall be applied between the EIFS and the wall sheathing.

**R703.9.3 Flashing, general.** Flashing of EIFS shall be provided in accordance with the requirements of Section R703.8.

**R703.9.4 EIFS/EIFS with drainage installation.** All EIFS shall be installed in accordance with the manufacturer's installation instructions and the requirements of this section.

**R703.9.4.1 Terminations.** The EIFS shall terminate not less than 6 inches (152 mm) above the finished ground level.

**R703.9.4.2 Decorative trim.** Decorative trim shall not be face nailed though the EIFS.

### **R703.10 Fiber cement siding.**

**R703.10.1 Panel siding.** Fiber-cement panels shall comply with the requirements of ASTM C 1186, Type A, minimum Grade II. Panels shall be installed with the long dimension either parallel or perpendicular to framing. Vertical and horizontal joints shall occur over framing members and shall be sealed with caulking, covered with battens or shall be designed to comply with Section R703.1. Panel siding shall be installed with fasteners according to Table R703.4 or approved manufacturer's installation instructions.

**R703.10.2 Lap siding.** Fiber-cement lap siding having a maximum width of 12 inches shall comply with the requirements of ASTM C 1186, Type A, minimum Grade II. Lap siding shall be lapped a minimum of 1<sup>1</sup>/<sub>4</sub> inches (32 mm) and lap siding not having tongue-and-groove end joints shall have the ends sealed with caulking, installed with an H-section joint cover, located over a strip of flashing or shall be designed to comply with Section R703.1. Lap siding courses may be installed with the fastener heads exposed or concealed, according to Table R703.4 or approved manufacturer's installation instructions.

**R703.11 Vinyl siding.** Vinyl siding shall comply with and be labeled as conforming to ASTM D 3679 and is permitted to be used on exterior walls in accordance with the manufacturer's approved installation instructions and Section R703.11.1 and R703.11.2.

**R703.11.1 Installation.** Vinyl siding, soffit and accessories shall be installed in accordance with the manufacturer's installation instructions and shall be capable of resisting the wind loads specified in Section R703.1.1.

**R703.11.1.1** Soffit panels shall be individually fastened to a supporting component such as a nailing strip, fascia or subfascia component or as specified by the manufacturer's instructions.

**R703.11.2 Foam plastic sheathing.** Vinyl siding used with foam plastic sheathing shall be installed in accordance with Section R703.11.2.2 or R703.11.2.3.

**Exception:** Where the foam plastic sheathing is applied directly over wood structural panels, fiberboard, gypsum sheathing or other *approved* backing capable of independently resisting the design wind pressure, the vinyl siding shall be installed in accordance with Section R703.11.1.

**R703.11.2.1** Reserved.

**R703.11.2.2 Design wind pressure.** Where foam plastic sheathing is used as a backing material, the design wind pressure rating of the vinyl siding for installation over solid sheathing as provided in the vinyl siding manufac-

turer's product specifications shall be adjusted for the following wall assembly conditions:

1. For wall assemblies with foam plastic sheathing on the exterior side and gypsum wall board or equivalent on the interior side of the wall, the vinyl siding's design wind pressure rating shall be multiplied by 0.39.
2. For wall assemblies with foam plastic sheathing on the exterior side and no gypsum wall board or equivalent on the interior side of wall, the vinyl siding's design wind pressure rating shall be multiplied by 0.27.

**R703.11.2.3 Manufacturer specification.** Where the vinyl siding manufacturer's product specifications provide an *approved* design wind pressure rating for installation over foam plastic sheathing, use of this design wind pressure rating shall be permitted and the siding shall be installed in accordance with the manufacturer's installation instructions.

**R703.12 Adhered masonry veneer installation.** Adhered masonry veneer shall be installed in accordance with the manufacturer's instructions.

**R703.13 Metal veneers.** Veneers of metal shall be fabricated from approved corrosion-resistant materials or shall be protected front and back with porcelain enamel, or otherwise be treated to render the metal resistant to corrosion. Such veneers shall not be less than specified in Table R703.13 mounted on wood or metal furring strips or approved sheathing on the wood construction.

**R703.13.1 Attachment.** Exterior metal veneer shall be securely attached to the supporting masonry or framing members with corrosion-resistant fastenings, metal ties or by other approved devices or methods capable of resisting the wind pressures specified in Table R301.2(2), but in no case less than 20 psf (0.958 kg/m<sup>2</sup>). Where the wind pressure determined in accordance with Table R301.2(2) do not exceed 30 pounds per square foot pressure (1.44 kN/m<sup>2</sup>), metal veneers are permitted to be attached in accordance with Table R703.4.

**R703.13.2 Weather protection.** Metal supports for exterior metal veneer shall be protected by painting, galvanizing or by other equivalent coating or treatment. Wood studs, furring strips or other wood supports for exterior metal veneer shall be approved pressure-treated wood or protected as required in Section 1403.2 of the *Florida Building Code, Building*. Joints and edges exposed to the weather shall be caulked with approved durable waterproofing material or by other approved means to prevent penetration of moisture.

**R703.13.3 Aluminum Siding.** Aluminum siding shall conform to the requirements of AAMA 1402.

**TABLE R703.13**  
**MINIMUM THICKNESS OF WEATHER COVERINGS**

COVERING TYPE	MINIMUM THICKNESS (inches)
Adhered masonry veneer	0.25
Anchored masonry veneer	2.625
Aluminum siding	0.019
Asbestos-cement boards	0.125
Asbestos shingles	0.156
Cold-rolled copper <sup>d</sup>	0.0216 nominal
Copper shingles <sup>d</sup>	0.0162 nominal
Exterior plywood (with sheathing)	0.313
Exterior plywood (without sheathing)	See Section 2304.6, of the <i>Florida Building Code, Building</i>
Fiberboard siding	0.5
Fiber cement lap siding	0.25 <sup>c</sup>
Fiber cement panel siding	0.25 <sup>c</sup>
Glass-fiber reinforced concrete panels	0.375
Hardboard siding <sup>c</sup>	0.25
High-yield copper <sup>d</sup>	0.0162 nominal
Lead-coated copper <sup>d</sup>	0.0216 nominal
Lead-coated high-yield copper	0.0162 nominal
Marble slabs	1
Particleboard (with sheathing)	See Section 2304.6, of the <i>Florida Building Code, Building</i>
Particleboard (without sheathing)	See Section 2304.6, of the <i>Florida Building Code, Building</i>
Precast stone facing	0.625
Steel (approved corrosion resistant)	0.0149
Stone (cast artificial)	1.5
Stone (natural)	2
Structural glass	0.344
Stucco or exterior Portland cement plaster	
Three-coat work over:	
Metal plaster base	0.875 <sup>b</sup> nominal
Unit masonry	0.625 <sup>b</sup> nominal
Cast-in-place or precast concrete	0.625 <sup>b</sup> nominal
Two-coat work over:	
Unit masonry	0.5 <sup>b</sup> nominal
Cast-in-place or precast concrete	0.375 <sup>b</sup> nominal
Terra cotta (anchored)	1
Terra cotta (adhered)	0.25
Vinyl siding	0.035
Wood shingles	0.375
Wood siding (without sheathing) <sup>d</sup>	0.5

For SI: 1 inch = 25.4 mm.

- Wood siding of thicknesses less than 0.5 inch shall be placed over sheathing that conforms to Section 2304.6.
- Exclusive of texture.
- As measured at the bottom of decorative grooves.
- 16 ounces per square foot for cold-rolled copper and lead-coated copper, 12 ounces per square foot for copper shingles, high-yield copper and ounces per square foot for copper shingles, high-yield copper and lead-coated high-yield copper.

**R703.14 Weather protection.** Exterior walls shall provide weather protection for the building. The materials of the minimum nominal thickness specified in Table R703.13 shall be acceptable as approved weather coverings.

**R703.15 Drained assembly wall over mass assembly wall.** Where wood frame or other types of drained wall assemblies are constructed above mass wall assemblies, flashing or other approved drainage system shall be installed as required by Section R703.8.

## SECTION R704 INSPECTION FOR TERMITES

In order to provide for inspection for termite infestation, clearance between exterior wall coverings and final earth grade on the exterior of a building shall not be less than 6 inches (152 mm).

### Exceptions:

- Paint or decorative cementitious finish less than  $\frac{5}{8}$  inch (17.1 mm) thick adhered directly to the masonry foundation sidewall.
- Access or vehicle ramps which rise to the interior finish floor elevation for the width of such ramps only.
- A 4-inch (102 mm) inspection space above patio and garage slabs and entry areas.
- If the patio has been soil treated for termites, the finish elevation may match the building interior finish floor elevations on masonry construction only.
- Masonry veneers constructed in accordance with Section R318.4.

