

TESTING APPLICATION STANDARD (TAS) No. 101-95
TEST PROCEDURE FOR STATIC UPLIFT RESISTANCE OF
MORTAR OR ADHESIVE SET TILE SYSTEMS

1. Scope

1.1 This Protocol covers the determination of: 1) the average weight (W) of a tile; 2) the restoring moment due to gravity (M_g) provided by the tile's weight; 3) the minimum characteristic resistance load (F); and, 4) the attachment resistance expressed as a moment (M_f) provided by the mortar or adhesive bond to the tile.

1.2 The test procedures outlined herein shall be used to determine: 1) the average mass (m) of the tile; and, 2) the resistance to an uplift load placed on a mortar or adhesive set tile installed on a test specimen which is set at a predetermined test slope (θ).

The point of application of the uplift load shall be dependent upon whether the system has been or is to be tested for wind characteristics in compliance with TAS 108.

Prior to conducting the testing, the tile system manufacturer shall specify to the testing agency a test slope (θ) of either 9.5° (2 in:12 in.) or 18.5° (4 in:12 in.).

1.3 The calculations outlined herein shall be used to determine: 1) the average weight (W) of the tile; 2) the restoring moment due to gravity (M_g), determined from knowledge of the tile's average weight (W) and dimensions, and the test slope (θ); 3) the minimum characteristic resistance load (F), which is representative of the test data noted in Section 1.2; and, 4) the attachment resistance expressed as a moment (M_f) provided by the tile's bonds at the test slope (θ).

1.4 All testing and calculations shall be conducted by an approved testing agency and all test reports, including calculations, shall be signed by a Registered Design Professional per F.S., Section 471 or 481.

1.5 A margin of safety of 2:1 shall be applied to test results, as noted in Section 10.4.1.

1.6 For the purposes of the testing required in TAS 101-95, design pressures calculated in accordance with ASCE 7 are permitted to be multiplied by 0.6.

2. Referenced Documents

2.1 *The Florida Building Code, Building*

2.2 *Application Standards*

TAS 108 Test Procedure for Wind Tunnel Testing of Air Permeable, Rigid, Discontinuous Roof Systems

RAS 127 Standard Procedure for Determining Applicability of Tile System Installation

2.3 *The American Plywood Association Performance Standards and Polices for Structural-Use Panels*

2.4 *Redland Technologies - New Technology & Product Development Centre Fixing Studies for MRTI Normal Weight Tiles - SBCCI Submission*

2.5 *The American Society of Civil Engineers (ASCE) ASCE 7; Minimum Design Loads for Buildings and Other Structures*

2.6 *ASTM Standards:*

E 380 Excerpts from the Standard Practice for Use of the International System of Units (SI) (the Modernized Metric System)

2.7 *Roof Consultants Institute Glossary of Terms*

3. Terminology & Units

3.1 Definitions - For definitions of terms used in this specification, refer to Chapters 2 and 15 (High-Velocity Hurricane Zones) of the *Florida Building Code, Building*;

and/or Fixing Studies for MRTI Normal Weight Tiles; and/or the RCI Glossary of Terms. The definitions from the *Florida Building Code, Building* shall take precedence.

- 3.2 Units - For conversion of U.S. customary units to SI units, refer to ASTM E 380.

4. Significance and Use

- 4.1 The test procedures and calculations specified herein provide a means for establishing: 1) the average weight (W) of the tile; 2) the restoring moment due to gravity (M_g) provided by the tile's weight; 3) the minimum characteristic resistance load (F'); and, 4) the attachment resistance expressed as a moment (M_r) provided by the tile's bonds.

The tile's average weight (W) is a measure of its gravitational force of attraction to the earth's surface. Sea level conditions are assumed for the purposes of this Protocol.

The tile's restoring moment due to gravity (M_g) is a measure of its ability to resist a rotational force (moment) prior to its attachment (bonding) to the substrate, when positioned at the specified test slope (θ). It represents the tile's weight in terms of resisting a rotational force.

The minimum characteristic resistance load (F') represents the combined effects of the tile's weight and its bond to the substrate in their ability to resist an uplift load placed at a predetermined location on the tile.

The attachment resistance expressed as a moment (M_r) is a measure of the bond's ability to resist the rotational force incurred upon it due to the uplift load placed on the tile.

- 4.2 Systems which are also tested for wind characteristics (henceforth 'moment based systems'), in compliance with TAS 108, shall have: 1) the restoring moment due to gravity (M_g); 2) the minimum characteristic resistance load (F'); and, 3) the attachment resistance expressed as a moment (M_r), determined under this Protocol, listed in the system manufacturer's Product Approval for reference. These

values are used, in conjunction with the system's aerodynamic multiplier (λ), also listed in the Product Approval, in the calculations and procedures outlined in RAS 127 to determine whether the mortar or adhesive bonding is acceptable for tile system installation on a particular building in the High-Velocity Hurricane Zone jurisdiction. While the calculations and procedures noted in RAS 127 may be conducted by the Uniform Building Permit applicant, where the pressures (P) have been determined based on Table 1 and do not require additional signed and sealed engineering design calculations. All other calculations shall be conducted by a Professional Engineer or Registered Architect.

- 4.3 Systems which are not tested for wind characteristics (henceforth "uplift based systems,") due to size constraints, air impermeability, or manufacturer decision, shall have: 1) the tile's average weight (W); 2) the tile's length (l) and width (w); and, 3) the minimum characteristic resistance load (F') listed in the system manufacturer's Product Approval for reference. These values are used in the calculations and procedures outlined in RAS 127 to determine whether the mortar or adhesive bonding is acceptable for tile system installation on a particular building in the High Velocity Hurricane Zone jurisdiction. While the calculations and procedures noted in RAS 127 may be conducted by the Uniform Building Permit applicant, where the pressures (P) have been determined based on Table 1 and do not require additional signed and sealed engineering design calculations. All other calculations shall be conducted by a Professional Engineer or a Registered Architect.

NOTE: Uplift based systems need only be tested for average weight (W) and minimum characteristic resistance load (F') in this Protocol.

- 4.4 Testing in compliance with this protocol and subsequent listing of the results in the system manufacturer's Product Approval, as noted in Sections 4.2 or 4.3, does not imply automatic approval for installation of the tested system on any building in the High-Velocity Hurricane Zone jurisdiction. The applicability of system installa-

tion shall be determined in one of the following two ways:

4.4.1 For exposure "C" buildings having a roof mean height less than or equal to 40 feet, the Uniform Building Permit applicant may utilize the procedures set forth in TAS 127 to determine whether or not a particular tile system may be installed on a particular building in the High-Velocity Hurricane Zone jurisdiction. The procedure outlined in Section 4.4.2 is also an option for those exposure "C" buildings having a roof mean height less than or equal to 40 feet.

4.4.2 The Authority Having Jurisdiction shall determine the acceptability of system installation based on results from engineering design calculations in compliance with RAS 127. These calculations shall be: 1) performed for all buildings having a roof mean height greater than 40 feet; 2) performed, signed and sealed by a Registered Design Professional per F.S., Section 471 or 481; and, 3) shall take precedence over the procedures outlined in Section 4.4.1.

5. Apparatus

5.1 The test apparatus shall consist of a steel framework and loading bar of sufficient strength to remain rigid when loads of up to 250 lbf are applied. The frame shall be fixed to a solid floor so as to prevent movement and provide a solid reference level for deflection measurements. (See Figure 1, attached.)

5.2 The loading bar position shall be adjustable along the frame width to facilitate the upward loading of the "test tile." The opposite end of the loading bar shall be attached to a hydraulic jack, or other similarly controllable mechanical device. (See Figure 1, attached.)

5.3 Tile Load Transfer (See Figure 1, attached)

5.3.1 Moment based systems shall have the static uplift load applied at a

point along the center of the tile, 0.76 x l (l = tile length) from the head of the tile.

5.3.2 Uplift based systems shall have the static uplift load applied at the center of the tile.

5.3.3 Prior to test specimen construction, install one of the following load transfer devices to the "test tile" at the appropriate location, as noted in Section 5.3.1 or 5.3.2, above.

- Drill a hole at the appropriate location in the "test tile" using a 0.203 in. - 0.205 in. nonpercussion, cutting carbide bit to minimize spalling. Discard any tile which, subsequent to drilling, exhibits spalling in excess of 1/4 in. Install a 1/4 in. diameter, threaded concrete anchor through the pre-drilled hole allowing for penetration not greater than 1/4 in.

or,

- Drill a hole at the appropriate location in the "test tile" using a 7/16 in. - 1/2 in. nonpercussion, cutting carbide bit to minimize spalling. Discard any tile which, subsequent to drilling, exhibits spalling in excess of 1/4 in. Cover the bottom of the predrilled hole with duct tape and fill the hole with epoxy. Insert a 3/8 in. diameter epoxy bolt into the hole and allow to cure for 24 hours prior to tile installation.

5.4 A load cell, attached to or forming part of the loading bar, shall be rigidly attached to the load transfer device, noted in Section 5.3.3, to measure the load applied. The load cell shall have a digital, dial or chart recorded output capable of recording loads up to 250 lbf and a resolution of 0.5%. The load cell shall be capable of recording the ultimate load incurred upon the "test tile." (See Figure 1, attached.)

5.5 Linear displacement gauges (i.e. dial gauges) shall be used to record the "test

tile” displacement. Gauges shall be firmly attached to the plywood substrate adjacent to the “test tile.” (See Figure 1, attached.)

- 5.6 A measurement device with an accuracy of 0.05 lbm shall be used to determine the average mass of the “test tiles.”

6. Test Limitations and Precautions

- 6.1 During the test, all testing agency representatives and other test observers shall wear eye protection to prevent injury.
- 6.2 The Protocol may involve hazardous materials, operations and equipment. This Protocol does not purport to address all of the safety problems associated with its use. It is the responsibility of the user to consult and establish appropriate safety and health practices and determine the applicability of regulatory limitations prior to use.
- 6.3 Care must be taken not to damage, twist or distort the test specimen during handling as this may affect the test specimen’s performance.

7. Test Specimen - 14 test specimens shall be constructed in compliance with the specification herein. Prior to test specimen construction, refer to Section 9.1 herein.

- 7.1 Deck
 - 7.1.1 The wood test deck shall consist of APA 32/16 span rated sheathing of $1\frac{5}{32}$ in. thickness installed over 2 in. x 6 in. perimeter supports and 2 in. x 6 in. intermediate supports spaced 24 in. apart. The sheathing shall be attached with 8d common nails at 6 in. o.c. at panel edges and 12 in. o.c. at intermediate supports. The sheathing shall be sized to accommodate the tile installation specified in Section 7.6 while meeting the size constraints of the steel test frame. The test deck shall be capable of resisting a minimum dead load of 55 psf.

7.2 Underlayment

- 7.2.1 Underlayment shall be a standard 30/90 system with a 30 lb. ASTM D 226, Type II anchor sheet and an ASTM D 6380 CLASS M mineral surface roll roofing as the top ply.

- 7.2.2 The anchor sheet shall be mechanically attached to the wood sheathing with 12 ga. roofing nails and $1\frac{5}{8}$ in. tin caps, in a 12 in. grid pattern staggered in two rows in the field and 6 in. o.c. attachment at any laps. The mineral surface top ply shall be applied in a full mopping of ASTM D 312, Type IV asphalt.

7.3 Mortar (if a mortar set tile system assembly)

- 7.3.1 Mortar mix shall have a roofing component Product Approval for use with the mortar set tile system and shall be in compliance with TAS 123.

- 7.3.2 Mortar shall be mixed using the mixing ratio specified in the mortar manufacturer’s Product Approval.

- 7.3.3 Mortar flow shall be determined using a cone penetrometer test, in compliance with ASTM C 780 (Appendix A1), the results of which shall be $2\frac{1}{8} \pm \frac{1}{8}$ in. (55 ± 3 mm) of penetration.

7.4 Adhesive (if an adhesive set tile system assembly)

- 7.4.1 Adhesive shall have a Roofing Component Product Approval for use with the adhesive set tile system which is being tested and shall be applied in compliance with the provisions set forth in that Approval.

7.5 Supplemental Adhesive (Optional)

- 7.5.1 The applicant may use a “dab” of adhesive applied to the underside of each “test tile” for additional component securement. The adhesive shall have a Roofing Component Product Approval for use with tile systems.

7.5.2 The tile adhesive shall be applied at the “test tile” headlap in a single $\frac{3}{8}$ in. wide x $1\frac{1}{4}$ in. long bead placed between $1\frac{1}{2}$ in. and 2 in. from the nose of the “test tile.”

7.8 The test specimen shall be inspected by a Registered Design Professional per F.S., Section 471 or 481 or Registered Roof Consultant who shall certify, in the final test report, that it was constructed in compliance with the provisions of this Protocol.

7.6 Tile

8. Conditioning

7.6.1 Tile shall have an identifiable mark confirming the manufacturer and shall be identified as a flat, low or high profile tile.

8.1 Conditioning shall consist of 21 days at outdoor ambient conditions in which the relative humidity reaches not less than $80\% \pm 10\%$ during not less than 5 of the 21 days and the surface temperature of the test panel reaches $120 \pm 5^\circ\text{F}$ for not less 4 hours during 10 of the 21 days.

7.6.2 Mortar set tile shall be applied in a bed of mortar, the amount of which shall be a 10 in. trowel filled with mortar which is in compliance with Section 7.3 of this Protocol. The 10 in. trowel of mortar shall be placed at the same location beneath each tile for every test specimen constructed. This locations shall be noted in the final report.

8.1.1 The surface temperature shall be measured with a surface mounted thermocouple and recorded on a chart recorder to confirm that the surface temperature meets the criteria noted in Section 8.1

7.6.3 Adhesive set tile shall be applied in the quantity of adhesive specified on the adhesive manufacturer’s roofing component Product Approval.

8.2 If the outdoor ambient conditions do not meet the requirements set forth in Section 8.1 during the 21 day conditioning period, additional conditioning time shall be incurred until these requirements are met.

7.6.4 All tile shall be applied with a minimum 3 in. head lap unless restricted by product design.

8.3 If the outdoor ambient condition requirements set forth in Section 8.1 cannot be achieved, conditioning shall consist of 336 hours (14 days) of which the first 120 hours (5 days) shall be in a controlled environment and the remaining 216 hours (9 days) shall be at outdoor ambient conditions.

7.6.5 The first course shall consist of two tiles installed at the lower edge of the test deck. The second course shall consist of the “test tile” installed over the first course, insuring for a minimum 3 in. headlap, unless restricted by product design. Tile in the first course which are not tested shall be installed to insure the “test tile,” in the second course, is at the correct angle relative to the sheathing.

7.7 During test specimen construction, measure and record the “test tile angle” (a); the angle between the bottom surface of the “test tile” and the substrate. Record this angle for each of the 14 test specimens and determine an average “test tile angle.”

Time Frame (Hour Number)		Peak Surface Temperature (°F)
Starting Hour	Ending Hour	
0	12	75 + 5
12	24	120 + 5
24	36	75 + 5
36	48	120 + 5
48	60	75 + 5
60	72	120 + 5
72	84	75 + 5
84	96	120 + 5
96	108	75 + 5
108	120	120 + 55

8.3.1 The first phase of conditioning shall consist of 120 hours (5 days)

during which the relative humidity is held at a constant $80\% \pm 10\%$ and the following surface temperature increments and decrements are attained. Each specified surface temperatures shall be sustained for not less than one continuous hour.

The temperature increase rate shall not exceed 10°F per hour.

8.3.2 The surface temperature shall be measured with a surface mounted thermocouple and recorded on a chart recorder to confirm that the surface temperature meets the criteria noted in Section 8.3.1.

8.3.3 Subsequent to the end of 120 hours, the test specimen shall be allowed to sit in outdoor ambient conditions for the remaining 216 hours (9 days).

8.4 Care must be taken not to damage, twist or distort the test specimen during handling. Such damage may adversely affect the bond's performance.

9. Procedure

9.1 Prior to installing the "test tiles" on the test specimen, determine the mass of the 14 "test tiles" to an accuracy of 0.05 lbm, tabulate the data and determine the average mass.

9.2 After test specimen conditioning is complete, mount one of the 14 test specimens on the test apparatus at the predetermined test slope (θ), as noted in Section 1.2.

9.3 Position the displacement device at the nose of the "test tile" to measure the displacement in the direction of the applied load.

9.4 Connect the loading and load measurement devices rigidly to the load transfer device, noted in Section 5.3.3, and apply an uplift load. Care shall be taken to ensure that the uplift load is applied vertically and that the tile's displacement rate does not exceed 2 in. per minute.

9.5 An observer shall monitor the tile, the mortar or adhesive bonds and the displacement gauges while a second observer monitors the load measuring device. Record the ultimate load at which: 1) the tile breaks or cracks; 2) the mortar patty or adhesive delaminates from the underlayment; 3) the tile delaminates from the mortar patty or adhesive; or, 4) the nose of the tile displaces vertically 2 in.

9.6 Repeat Sections 9.2 through 9.5 for each of the remaining test specimens and tabulate the ultimate uplift loads.

10. Calculations

10.1 Weight (W)

10.1.1 Determine the average weight of the 14 "test tiles" using the average mass of these tiles, determined in Section 9.1, and the following equation.

$$W = mx \times \frac{1 \text{ slug}}{32.174 \text{ lbm}} \times g$$

where,

W = average tile weight (lbf);
m = average tile mass (lbm); and,
g = 32.2 ft/s^2 = acceleration of gravity constant.

Note: 1 slug = 1 lbf s²/ft

10.2 Restoring Moment due to Gravity (M_g)

NOTE: This calculation need only be performed for moment based systems.

10.2.1 Determine the restoring moment due to gravity (M_g) at the test slope (θ) using the tile's average weight (W), determined in Section 10.1, the "test tile angle" (α), determined in Section 7.7, and the following equation.

$$M_g = W \times \cos(\theta - \alpha) \times L_g$$

where,

M_g = restoring moment due to gravity (ft-lbf);

W = tile's average weight (lbf);
 L_g = tile's gravitational moment arm (ft);
 θ = test slope (degrees); and,
 α = "test tile angle" (degrees)

Notes:

1. The tile's gravitational moment arm (L_g) is the orthogonal distance from the tile's center of gravity to its axis of rotation.
2. For S shaped clay or concrete tile, the axis of rotation is located toward the upper left corner of the tile. A gravitational moment arm of $L_g = 0.728$ feet has been found to be typical of this type of tile. The testing agency shall confirm this value through measurement prior to use in the above noted equation.
3. For all other tile, $L_g = (0.5 \times l)$ where l = tile length

10.3 Statistical Analysis of Test Data

10.3.1 From the 14 recorded ultimate loads, eliminate the high and low values leaving 12 ultimate load values for statistical analysis.

10.3.2 Determine the mean ultimate load (F) and the standard deviation (S_F) using the tabulated data and the following equations.

$$\bar{F} = \frac{1}{12} \sum_{i=1}^{12} F_i \quad \text{and,}$$

$$S_F = \sqrt{\frac{1}{11} \sum_{i=1}^{12} (F_i - \bar{F})^2} \quad \text{where,}$$

\bar{F} = mean ultimate load;
 S_F = standard deviation;
 F = recorded ultimate load; and,
 i = 1, 2,, 12 = test number.

10.3.3 Determine the percent deviation from the mean (S'_F) using the information from Section 10.3.2 and the following equation.

where,

$$S'_F = \left(\frac{S_F}{F} \right) \times 100$$

S'_F = percent deviation from the mean (%);

S_F = standard deviation; and,

\bar{F} = mean ultimate load.

10.3.3.1 If the percent deviation from the mean (S'_F) is greater than or equal to 20%, then the test results shall be considered null and void and the test shall be considered a re-test.

10.4 Minimum Characteristic Resistance Load (F')

10.4.1 The mean ultimate load, \bar{F} , used to determine the minimum characteristic resistance load (F') shall be adjusted when the attachment system is used to provide resistance to more than one (1) roof tile by dividing the mean ultimate load by a load factor. For systems where the attachment provides resistance to a single roof tile the load factor shall be 1. For systems where the attachment provides resistance for two (2) roof tiles the load factor shall be 2. For systems where the attachment provides resistance for more than two (2) roof tiles the load factor shall be calculated and applied.

$$\bar{F} \equiv \frac{\bar{F}}{\text{LoadFactor}}$$

10.4.2 Determine the minimum characteristic resistance load (F') using the mean ultimate load (F) and the following equation.

$$F' = \left(\frac{\bar{F} - W}{MS} \right) \quad \text{where,}$$

F' = minimum characteristic resistance load;

\bar{F} = mean ultimate load;

MS = margin of safety = 2; and,

W = average weight.

NOTE: The requirement noted in Section 10.3.3.1 shall be met prior to determining the minimum characteristic resistance load (F').

10.5 Attachment Resistance Expressed as a Moment (M_f)

NOTE: This calculation need only be performed for moment based systems.

10.5.1 Determine the attachment resistance expressed as a moment (M_f) provided by the tile’s bond at test slope (θ) using the minimum characteristic resistance load (F'), determined in Section 10.4.1, the “test tile angle” (α), determined in Section 7.7, and the following equation.

$M_f = [F' \times \cos(\theta - \alpha) \times L_f]$ where,

M_f = attachment resistance (ft-lbf);

F' = minimum characteristic resistance load (lbf);

L_f = tile’s attachment moment arm (ft);

θ = test slope (degrees); and,

α = test tile angle (degrees).

NOTES:

1. The tile’s attachment moment arm (L_f) is the orthogonal distance from the point of load application to its axis of rotation.

2. For all tile other than S-shaped clay or concrete tile:

$L_f = (0.76 \times l)$ where, l = tile length

3. For S- shaped clay or concrete tile, the axis of rotation is located toward the upper left corner of the tile. For this reason the tile’s attachment moment arm (L_f) shall be measured for the S shaped clay or concrete tile in question. Measure the orthogonal distance from the point of load application (as noted in Section 5.3.1) to the axis of rotation. This distance is the tile’s attachment moment arm (L_f).

11. Report

11.1 The final test report shall include the following:

11.1.1 A description and sketch of the mortar or adhesive set tile, including the manufacturer and type of tile (i.e., flat or high profile).

11.1.2 A statement of which load transfer device, noted in Section 5.3, was utilized and which test slope (θ) was selected by the manufacturer.

11.1.3 A detailed report of the method of test specimen construction, including a photograph of the test specimen and certification by a Registered Design Professional per F.S., Section 471 or 481 or Registered Roof Consultant that the test specimen was constructed in compliance with the specifications of this Protocol.

11.1.4 Recorded surface temperature results confirming compliance with the conditioning requirements set forth in Section 8.

11.1.5 Tabulated results of mass measurements of the 14 “test tiles” and an average mass.

11.1.6 Tabulated “test tile angle” (α) measurements for the 14 test specimens and an average “test tile angle.”

11.1.7 Tabulated ultimate load measurements (F1, F2, F3, . . . F12) for the 14 test specimens.

11.1.8 Average tile weight (W) calculations and results.

11.1.9 Restoring moment due to gravity (M_g) calculations and results (needed only for moment based systems).

11.1.10 Calculations and results confirming the percent deviation from the mean (S'_f) less than 20%.

11.1.11 Minimum characteristic resistance load (F') calculations and results.

11.1.12 Attachment resistance expressed as a moment (M_f) calculations and results (needed only for moment based systems).

11.1.13 A video tape of all pertinent aspects of the test, including test specimen construction and uplift load application.

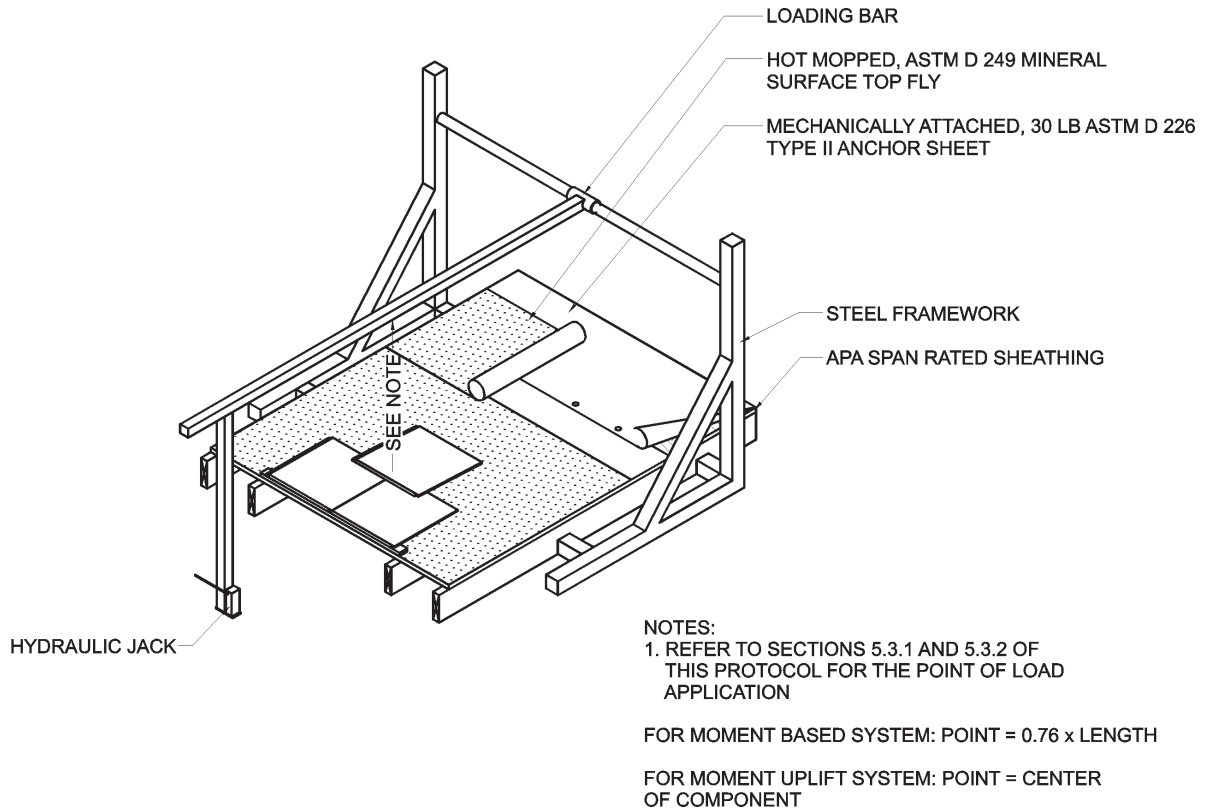

FIGURE 1
STATIC UPLIFT APPARATUS

