

# TESTING APPLICATION STANDARD (TAS) No. 111(B)-95

## TEST PROCEDURE FOR EDGE METAL PULL-OFF PERFORMANCE

### 1. Scope

- 1.1 This protocol covers determination of the pull-off resistance performance of various edge metal configurations when subjected to uniform loading.
- 1.2 The test procedures outlined in this protocol determine the resistance to uniform loading of an edge metal configuration, such as drip edge, gravel stop or metal profile, as required in RAS 111. Resistance to uniform loading is determined for the horizontal (deck) flange (upward loading) and the vertical (face) flange (outward loading).
- 1.3 All testing and calculations shall be conducted by an approved testing agency and all test reports, including calculations, shall be signed by a Registered Design Professional per F.S., Section 471 or 481.

### 2. Referenced Documents

- 2.1 *ASTM Standards:*
  - E 380 Excerpts from the Standard Practice for Use of the International System of Units (SI) (the Modernized Metric System)
- 2.2 *The Florida Building Code, Building.*
- 2.3 *Application Standards:*
  - RAS 111 Standard Requirements for Attachment of Perimeter Woodblocking and Metal Flashings
- 2.4 *Single Ply Roofing Institute:*  
SPRI Edge Design Guide, March 1994
- 2.5 *Roof Consultants Institute:*  
Glossary of Terms

### 3. Terminology & Units:

- 3.1 Definitions—For definitions of terms used in this specification, refer to Chapter 2 and Section 1513 of the *Florida Building Code, Building*; and/or the RCI Glossary of Terms. The definitions from the *Florida Building Code, Building* shall take precedence.
- 3.2 Units—For conversion of U.S. customary units to SI units, refer to ASTM E 380.

### 4. Significance and Use:

- 4.1 The test procedure outlined herein provides a means for determining the maximum upward and outward pressures which a perimeter edge metal system can resist without failure.
- 4.2 Results from this testing are used to determine whether a proposed perimeter edge metal system will provide sufficient resistance to upward and outward pressures to meet or exceed corresponding design pressures for perimeter and corner areas of a particular building, determined in compliance with Section 6 of RAS 111.

### 5. Apparatus:

- 5.1 Load application device:
  - 5.1.1 The load application device shall consist of a tensile tester, or other device capable of providing uniform load, fitted with a load cell capable of recording loads up to 10,000 lbf.
  - 5.1.2 The load application device shall be fitted with an 11 foot long clamp or a series of ten 2 inch wide clamps capable of grasping a series of ten 12 ga. annular ring shank nails which form part of the load transfer device.

- 5.2 Load transfer device:
- 5.2.1 The load transfer device shall consist of a 1 inch wide x 11 foot long x  $\frac{1}{8}$  inch thick steel bar with  $\frac{1}{8}$  inch diameter predrilled holes spaced 12 inches o.c. with the two end holes located  $\frac{1}{2}$  inch from each end of the bar.
- 5.2.2 The 11 feet long steel bar shall be mounted to the underside of the flange or load resisting component of the edge metal using 12 ga. x  $1\frac{1}{2}$  inch long annular ring shank nails.
- 5.3 A schematic of the test apparatus is provided in Figure 1, herein.
- 5.4 The description of the test apparatus is general in nature and may be altered for ease of testing, provided the intent of the test is maintained.

**6. Test Limitations and Precautions:**

- 6.1 This protocol may involve hazardous materials, operations and equipment. This protocol does not purport to address all of the safety problems associated with its use. It is the responsibility of the user to consult and establish appropriate safety and health practices and determine the applicability of regulatory limitations prior to use.

**7. Test Specimen:**

- 7.1 The test specimen shall consist of a 10 foot long “mock-up” of the edge metal as it would be installed in an actual field application. Not less than five test specimens shall be constructed and tested for each directional load (i.e., upward for deck flange and outward for vertical flange/face).
- 7.2 Prior to installation of the edge metal test specimen to its substrate, install the 11 foot long steel bar (load transfer device) through the back of the flange or load resisting component which is to be tested (i.e. deck flange, face flange or face cleat or hook strip) using 12 ga. x  $1\frac{1}{2}$  inch long annular ring shank nails such that the points of the nails are directed outwardly

normal from the load resisting component. (See Figure 1, herein.)

**8. Procedure:**

- 8.1 Photograph the test specimen prior to testing.
- 8.2 Position the test specimen, fitted with the load transfer device, in front of the load application device (tensile tester) and attach the 11 foot long clamp or series of ten clamps to the ends of the load transfer nails such that the clamp(s) do not interfere with the movement of the edge metal whatsoever and load generated from the load application device is normal to the surface of the edge metal flange or load resisting component being tested.
- 8.3 Apply an initial load of 300 lbf to the load transfer device and hold the applied load for a period of one minute. At the end of one minute, reduce the load to zero and allow the test specimen to sit at zero-load for a period of two minutes. Thereafter, increase the applied load to 350 lbf and hold the applied load for a period of one minute. At end of one minute, reduce the load to zero-load and allow the test specimen to sit at zero-load for a period of two minutes. Continue this procedure in load increments of 50 lbf until failure, as defined below, occurs.
- 8.3.1 Failure is defined as any occurrence of the following:
- loss of securement;
  - permanent deformation; or,
  - component failure that will not allow the edge metal to perform as designed.
- 8.4 Photograph the test specimen subsequent to failure.
- 8.5 Record the failure load and the time at which failure occurred for each of five test specimens and calculated an average failure load.

**9. Interpretation of Results:**

- 9.1 Convert the average failure load to pressure using the following equation:

where:

- P = maximum pressure (psf);
- F = average failure load (lbf); and,
- A = area of flange or load resistance component

- 9.2 The maximum pressure (outward or upward) shall meet or exceed corresponding design pressures for perimeter and corner areas of a particular building, determined in compliance with Section 6 of RAS 111.

**10. Report:**

- 10.1 The final report shall include the following:

- 10.1.1 A complete description of the edge metal system, including edge metal type, material, thickness and attachment, cleat or hook strip type, material, thickness, dimensions and attachment (if any), and the attachment substrate (i.e. woodblocking, etc.)

- 10.1.2 Recorded failure loads for each of five test specimens, an average failure load and a maximum pressure of the edge metal system.

- 10.1.3 Photographs of the test specimens prior and subsequent to failure.

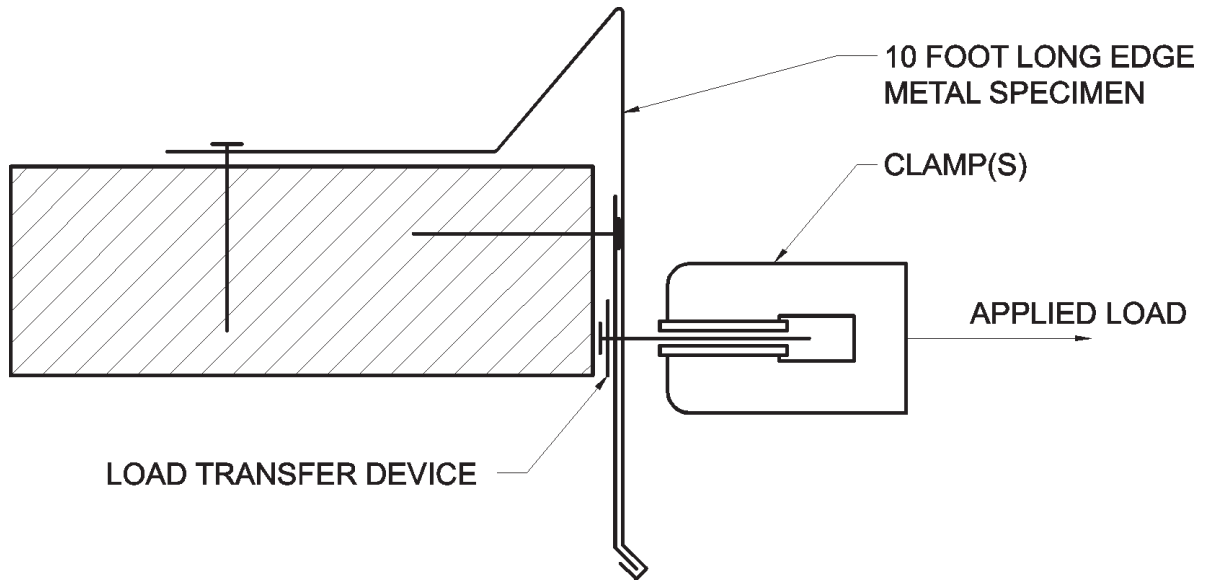

**FIGURE 1**  
**VIEW OF OUTWARD LOADING OF EDGE METAL VERTICAL FLANGE**  
**(UPWARD LOADING OF HORIZONTAL FLANGE ALSO REQUIRED)**